

OPERATOR'S MANUAL

Model WTKH-L

Hydraulic Loader Broom

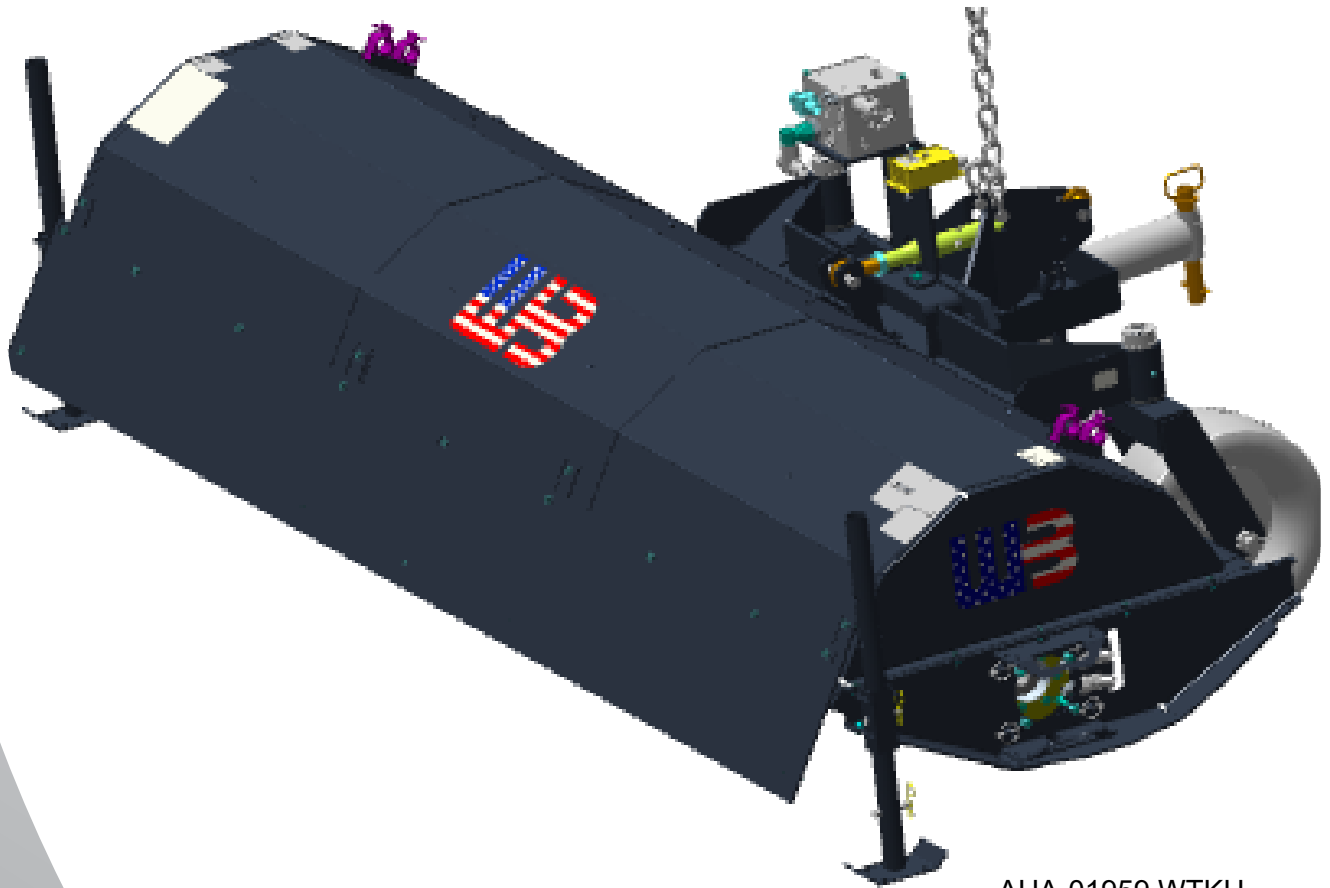

AHA-01959 WTKH



WB© WERK-BRAU CO., INC.
FINDLAY, OH USA
1-800-537-9561
MANUFACTURED BY M-B COMPANIES, INC.
NEW HOLSTEIN, WI USA
1-800-558-5800

| | |
|---|----|
| NOTES | 1 |
| INTRODUCTION | |
| Operator's Manual | 2 |
| Identification Numbers | 2 |
| SAFETY | |
| Safety Alerts..... | 3 |
| Safety Decals..... | 3 |
| Pre-Start Guidelines..... | 3 |
| Operation Guidelines | 3 |
| Maintenance Guidelines | 4 |
| INSTALLATION | 5 |
| SETUP AND ADJUSTMENTS | |
| Setup..... | 6 |
| Pattern Adjustment..... | 6 |
| OPERATION | |
| Pre-Startup Checks..... | 7 |
| Travel Procedure | 7 |
| Operation | 7 |
| MAINTENANCE | |
| Maintenance Schedule | 8 |
| Lubrication | 8 |
| Filler Replacement..... | 8 |
| Core Removal | 8 |
| Brush Removal..... | 9 |
| Brush Installation..... | 9 |
| Core Installation | 9 |
| STORAGE | 10 |
| TROUBLESHOOTING | 11 |
| SPECIFICATIONS | 12 |
| BRUSH REFILL KITS | 13 |
| WARRANTY | 14 |
| PARTS BREAKDOWNS CAN BE FOUND IN THE BACK OF THIS MANUAL | |

NOTES

INTRODUCTION

OPERATOR'S MANUAL

You must read, understand and comply with all the safety and operating instructions in this manual before attempting to set-up and operate your power broom.

Failure to comply with the safety and operating instructions can result in loss of machine control, serious personal injury to you and/or bystanders, and risk of equipment and property damage.

IDENTIFICATION NUMBERS

When contacting your authorized dealer for information, replacement parts or service, you **MUST** have the model and serial number of your unit.

Record the serial number in the space provided. The serial number plate/decals can be found in the location shown in Figure 1.

| | |
|--------------------|-----------|
| Model Name/Number: | |
| Date Purchased: | Serial #: |



WB

WB® WERK-BRAU CO., INC.
FINDLAY, OH USA
1-800-537-9561
MANUFACTURED BY M-B COMPANIES, INC.
NEW HOLSTEIN, WI USA

SERIAL NUMBER
WB-00000

Figure 1

SAFETY

SAFETY ALERTS

Signal words and alert symbols notify of important safety precautions.

DANGER!



Indicates a hazardous situation which, if not avoided, will result in serious injury or death.

WARNING!



Indicates a hazardous situation which, if not avoided, could result in serious injury or death.

CAUTION!



Indicates a hazardous situation or unsafe practice which, if not avoided, could result in minor or moderate injury or property damage.

SAFETY DECALS

Although reading this manual and the safety instructions it contains will provide you with the necessary basic knowledge to operate this equipment safely and effectively, we have placed several safety labels on the unit to remind you of this important information while you are operating your unit.

All DANGER, WARNING, CAUTION, and instructional messages on your unit should be carefully read and obeyed. Bodily injury can result when these instructions are not followed. The information is for your safety and it is important.

These labels will act as a constant visual reminder to you, and others who may use the equipment, to follow the safety instructions necessary for safe, effective operation.

If any of these labels are lost or damaged, replace them at once. See your local dealer for replacements.

CAUTION

Read Operator's Manual before using broom. If operating instructions are missing, contact the M-B Co. for your free replacement.

- Before operating broom make sure all guards and broom are installed properly.
- Wear eye protection when operating broom.
- Do not operate broom near any objects that can be damaged by thrown debris. Be sure no by-standers are near broom during operation.
- The polypropylene brush segments can melt or burn. Do not subject to excessive heat or flame.
- Do not allow riders on broom.
- Stop power source, lower broom to the ground, set parking brake, and remove ignition key before servicing or adjusting.
- Do not operate broom on any roof or other elevated surface.

395-11251

WARNING

MOVING PART HAZARD

To prevent serious injury or death from moving parts:

- Close and secure guards and shields before starting.
- Keep hands, feet, hair and clothing away from moving parts.
- Disconnect and lockout power source before adjusting or servicing.
- Do not stand or climb on machine when operating.

395-11250

DANGER

To prevent serious injury or death:

- Do not allow any riders

395-11254

PRE-START GUIDELINES

- Install any covers or guards which may have been removed for shipping purposes.
- Before starting equipment, walk around equipment, making a visual inspection that all safety devices are properly installed and secured.
- Check that all hardware, fasteners, hydraulic fittings, etc. are in good condition and properly fastened. Replace any fatigued or damaged items with proper replacements.
- Personnel who are not required to be in the work area should be kept away. Never start the equipment unless you are absolutely certain that everyone in the area is clear of the machine and aware it is being started.
- Follow the manufacturer's recommended start-up procedure.

OPERATION GUIDELINES

Read, understand and follow all instructions in the manual and on the unit before starting.

NOTE: All reference to left, right, front or rear are given from the operator position and facing forward.

- To avoid serious injury or death, do not modify equipment. Any modifications made to equipment can be dangerous and can void equipment warranty.
- Never defeat a safety device to make a task easier.
- Always wear proper apparel when operating equipment; safety glasses, face shield or goggles, ear protection, and dust mask. Tie hair back. Never wear loose clothing or jewelry that could get caught in moving parts.
- Never operate equipment with covers or guards removed. Rotating parts can cause severe injury. Keep hands, feet, hair, jewelry and clothing away from all moving parts.
- Only allow responsible adults who are familiar with the instructions, to operate the unit (local regulations can restrict operator age).
- Clear the area of objects such as rocks, toys, wire, etc., which could be picked up and thrown.
- Be aware of surroundings. Be sure the area is clear of other people, bystanders or pets. Stop unit if anyone enters the area.

SAFETY

- Always look down and behind before and while traveling in reverse.
- Be aware of discharge direction and do not point discharge at anyone. Do not point the discharge at glass enclosures, automobiles, or windows.
- Always stand clear of the discharge area when operating this unit.
- Disengage all clutches and PTOs before starting engine.
- Never leave a running machine unattended. Always disengage the attachment and traction controls, lower the attachment, set the park brake, stop the engine and remove the ignition key before leaving the machine.
- Operate only in daylight or good artificial light.
- Never carry passengers.
- Do not operate the unit while under the influence of drugs, alcohol or other medication.
- Watch for traffic when operating near or crossing roadways.
- Use extra care when loading or unloading the unit into a trailer or truck.
- Keep in mind the operator is responsible for accidents occurring to other people or property.
- Data indicates that operators, age 60 years and above, are involved in a large percentage of power equipment-related injuries. These operators should evaluate their ability to operate the unit safely enough to protect themselves and others from injury.
- All operators should seek and obtain professional and practical instruction.
- Protect eyes, face and head from objects that may be thrown from unit. Wear appropriate hearing protection.
- Always wear substantial footwear and appropriate clothing. Wear footwear that improves traction on slippery slopes. DO NOT wear long scarves or loose clothing that could become entangled in moving parts.
- Abnormal Vibrations are a warning of trouble. Striking a foreign object can damage unit. Stop unit and engine. Wait for all moving parts to stop. Inspect unit and make any necessary repairs before restart.
- Never place your hands or any part of your body or clothing inside or near any moving part while unit is running.
- Stop engine before: refueling, cleaning, making adjustments or removing the attachment assembly.
- Follow the drive unit manufacturer's recommendations for wheel weights or counter weights.
- Make any adjustments before operating unit.
- Do not touch parts which may be hot from operation. Allow such parts to cool before attempting to service the unit.
- Before using, always visually check that hardware is present, intact and secure. Replace worn or damaged parts.
- Never operate the machine with damaged guards, or without safety protective devices in place.
- Follow the manufacturer's recommendations for towing weight restrictions and procedures.
- Original purchaser of this unit was instructed by the seller on safe and proper operation. If unit is to be used by someone other than original purchaser; loaned, rented or sold, ALWAYS provide this manual and any needed safety training before operation.
- The Operator must understand the functions and parameters of all controls and how to operate, as well as how to STOP in an Emergency.

MAINTENANCE GUIDELINES

- Maintain or replace safety and instruction decals/labels as necessary.
- Never run a unit in an enclosed area.
- Keep nuts and bolts tight and keep equipment in good condition
- Never tamper with safety devices. Check their proper operation regularly and make necessary repairs if they are not functioning properly.
- Keep unit free of debris and build-up. Clean up any oil spillage.
- Never make adjustments or repairs with the engine running unless specified otherwise in the engine manufacturer's manual.
- Components are subject to wear, damage, and deterioration. Frequently check components and replace with the manufacturer's recommended parts, when necessary.
- Check control operation frequently. Adjust and service as necessary.
- Use only factory authorized parts when making repairs.
- Always comply with factory specifications on all settings and adjustments.
- Only authorized service locations should be utilized for major service and repair requirements.
- Never attempt to make your own repairs on this unit unless you have been properly trained. Improper service procedures can result in hazardous operation, equipment damage and voiding the manufacturer's warranty.
- Stop engine on tractor and set parking brake before performing any adjustments on the machinery.
- Do not disassemble a pressurized system unless properly trained and equipped with adequate tooling.
- Escaping hydraulic fluid under pressure can have sufficient force to penetrate the skin, causing serious injury. Before operation, be sure that all hydraulic connections are tight and hoses are not damaged. Relieve pressure in system before making adjustments.
- Oils and fluids can be very hot under pressure. Use caution and allow the system to cool before beginning maintenance work.
- Never operate or pressurize one of these systems with worn or damaged components. Replace hoses, fittings, valves or other components which appear defective.
- Never adjust pressurized systems beyond recommended levels to achieve higher operating pressures.
- NEVER search for hydraulic leaks with only your hands. Use cardboard or a piece of wood.
- For engine equipped models, follow specific engine manufacturer's recommended service intervals for dirty/dusty environments.

INSTALLATION

INSTALLATION

The broom is shipped partially disassembled to conserve shipping space and to package securely to reduce the possibility of damage in transit. Remove all components from the shipping crate and place in a secure location.

NOTE: The broom mounting components shown throughout this instruction are representative only. Actual mounting components will be specific to the prime mover type and brand.

1. Remove the bucket or other attachment from the loader arms disconnecting the quick-attach.
2. Use quick-attach to secure the mounting frame to the loader. It may be easier to remove the swing cylinder before connecting the mounting frame and hitch frame. Position the loader with the mounting frame behind the broom and hitch frame assembly. See Figure 2



Figure 2

3. Pin broom and hitch assembly together using supplied center pin, nut, and cotter pin. See Figure 3

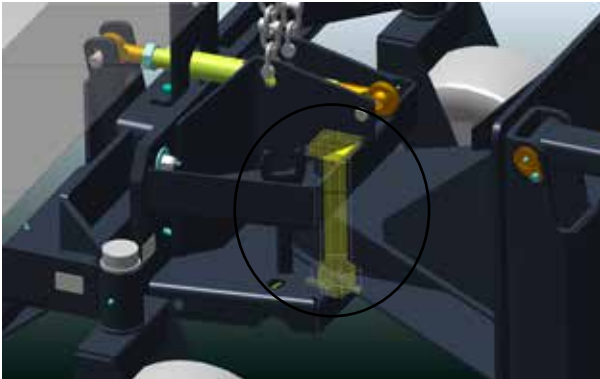

Figure 3

4. Attach hydraulic pressure and return hoses to electric/hydraulic angle valve.

(Note: hoses and hydraulic quick couplers not included).
(Required hydraulic hose specification -1 1/4 male O-ring boss, SAE 1 5/8 - 12 thread, 3000 psi minimum rating.)

Valve markings - See Figure 4
P = Hydraulic supply from loader
T = Hydraulic return to tank

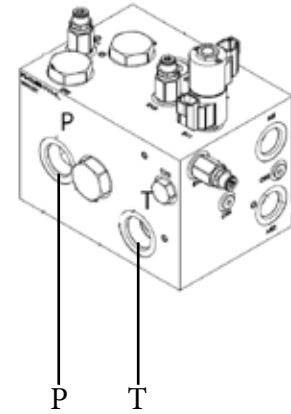

Figure 4

5. Lower the loader arms until caster wheels contact pavement

6. Using the loader dump cylinders, rotate the broom until the mounting plate is parallel to the ground. See Figure 5



Figure 5

7. Disable the dump cylinders by locking the control lever or disconnecting the hoses. This will prevent the frame from being tipped out of adjustment.

8. Connect supplied control box to power supply per provided electrical schematic part # 703-202409

9. Route and secure control box harness to broom.

10. Connect control box harness connectors to electric/hydraulic valve stacked coils. See figure 6

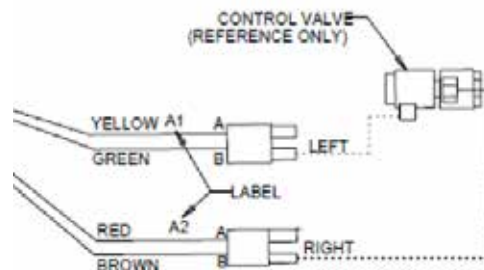

Figure 6

SETUP AND ADJUSTMENTS

SETUP

Proper setup and leveling of your power broom will increase the life of the brush and produces more efficient movement of material. Visually inspect the adjustments on the broom before each operating session and measure the adjustments once every 10 hours.

The following procedures must be followed in the prescribed order in order to be effective.

Once the broom has been properly adjusted, a short operation period is recommended for break-in; approximately 15 minutes. After this break-in period repeat the leveling procedure to ensure that it is correct. Mounting instructions can be found in the prime mover instruction manual.

PATTERN ADJUSTMENT

See Figure 7.

To set the brush pattern (swept area).

1. With the unit on a flat level surface, loosen the jam nut on the brush frame end of the actuator rod.
2. Turn the hex on the body of the actuator to adjust its length to raise/lower broom. Lengthening the actuator will lower the broom, creating more contact.
3. Tighten the jam nut on the brush frame end of the actuator rod.
4. Confirm adjustment by running the broom for about 30 seconds in the down position while stationary. Stop the broom and move the unit away. The 'cleaned' area (contact patch) should be 2-4" wide from front to rear for the entire length of the broom (Figure 8).

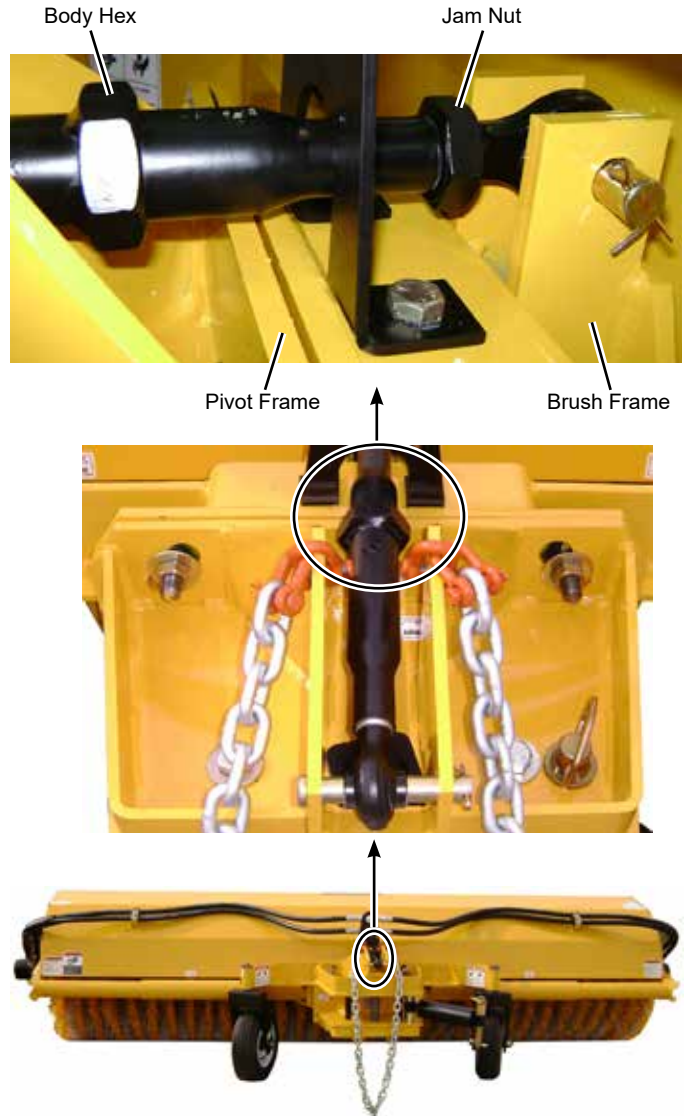

Figure 7

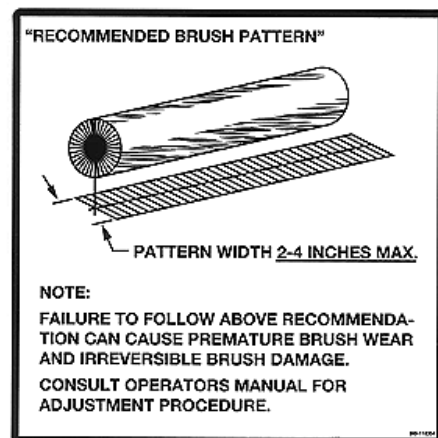

Figure 8

OPERATION

PRE-STARTUP CHECKS

IMPORTANT!

You must read, understand and comply with all the safety and operating instructions in this manual before attempting to set-up and operate your power broom. Failure to comply with the safety and operating instructions can result in loss of machine control, serious personal injury to you and/or bystanders, and risk of equipment and property damage.

1. Visually inspect equipment and hardware to ensure that all parts are secure and all hardware is tightened and secure.
2. Check for oil leaks and loose hose connections.
3. Inspect the broom adjustments to ensure that the broom is level and that there is a proper brush pattern. Refer to the **Setup and Adjustment** section of this manual.
4. Inspect the bristle length to determine if replacement segments are needed.

TRAVEL PROCEDURE

Follow these instructions for extended travel (i.e. to and from the sweeping site):

- Set broom rotation control to the OFF position.
- Use the lift control to bring the broom to the fully raised position.
- Raise the broom support stands to the highest position and secure in place.

OPERATION

IMPORTANT!

The support stands should never be used for anything other than as stationary storage stands to hold the broom up while it is being stored.

- Ensure the support stands are raised to the highest position and secured in place.
- Sweep at a speed that is appropriate for the conditions and location.
- For heavy material such as gravel or stones, drive more slowly with a higher broom speed. For lighter material, drive faster with a lower broom speed.
- It may be necessary to increase broom contact pattern under some conditions. If the surface being swept is uneven and causes the broom to leave upswept patches, increase the pattern size to compensate.
- If the material being swept is dried-on or difficult to remove, such as mud or ice, it may be necessary to drive extremely slow to allow the broom to "scrub" the surface. If the material being swept is dried-on or difficult to remove such as mud or ice, it may be necessary to drive extremely slow to allow the broom to "scrub" the surface.

MAINTENANCE

MAINTENANCE SCHEDULE

- Check adjustments – every 10 hours
- Grease bearings – after initial 10 hours, then every 200 - 300 hours thereafter.
- Grease pivot points – every 50 hours

NOTE: Grease points are noted with an applicable decal.



- Check and refill oil level – every 50 hours
- Replace oil filter – every 250 hours
- Replace hydraulic oil – annually
- Replace brush filler – as needed

LUBRICATION

- Grease bearings and pivot points per the MAINTENANCE SCHEDULE using Chevron Ultra Duty II, Grade 2; or equivalent high-temp grease.
- There are minimum of (13) grease points on the unit; (4) on the brush frame horizontal tubes, (2) on the brush frame caster wheel tubes, (2) on the caster wheel hubs, (3) on the pivot frame, and (2) on the brush core support bearings.
- Use an ISO 32 or greater hydraulic fluid, dependant upon operating temperatures, for M-B supplied independent hydraulic systems. If the oil is supplied by the prime mover, use the prime mover manufacturer's recommended fluid.

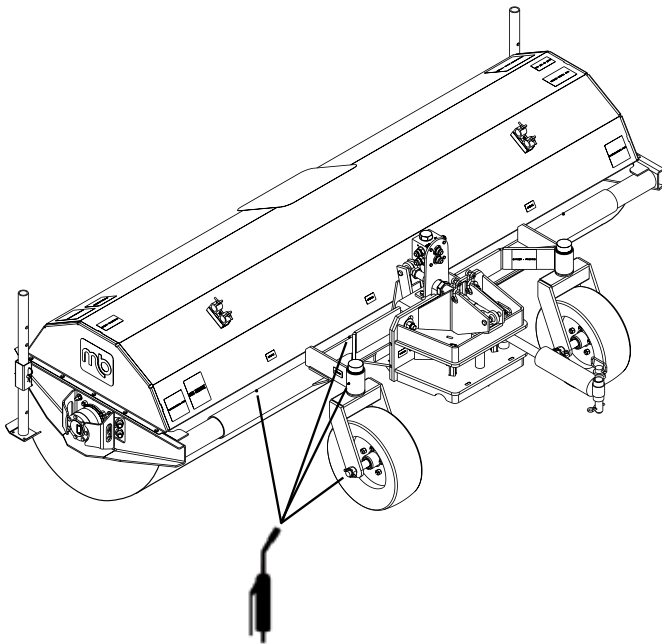

FILLER REPLACEMENT

Core Removal

1. Lower broom until brush contacts the ground.
2. Remove (4) lynch pins from brush frame. Retain mounting hardware. See Figure 9.

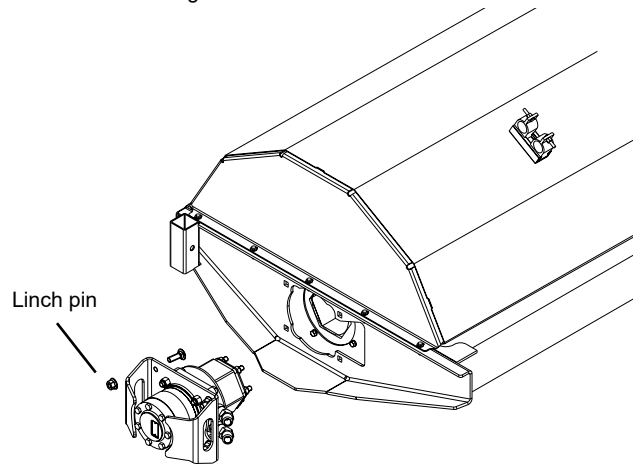

Figure 9

CAUTION! Support the broom hood when removing the hydraulic motors. The broom is driven and supported by the hex hub attached to the motor. When they motors are pulled out the hood or broom may move.



3. Slide motor out of mating hub. Let motor hang on hoses. Retain mounting hardware.
4. Raise the broom hood.
5. Slide core out the front of broom.

MAINTENANCE

Brush Removal

1. Remove (4) capscrews, lock washers and end disc (wafer retainer plate) from one end of core. Retain end disc and mounting hardware. See Figure 10.
2. Slide spent brush wafers and spacers off core and discard.

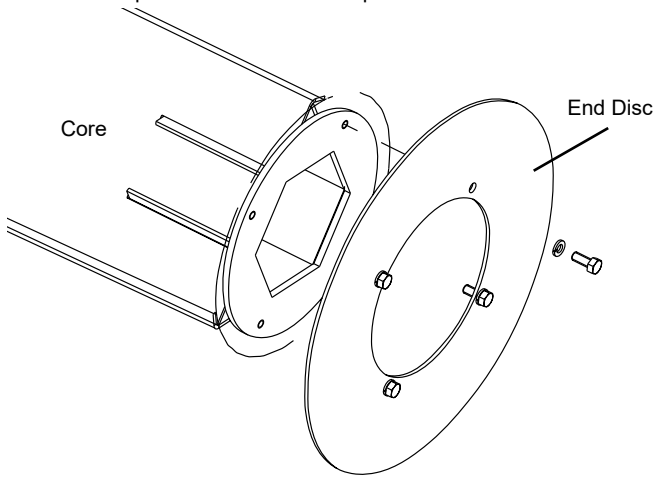

Figure 10

Brush Installation

NOTE: Always start and finish with a poly wafer.

1. Stand core in upright position and begin filling by sliding a poly brush wafer and then a spacer down the full length of the core.
2. Note the location of the drive pin on the inside ring of each brush wafer. Position each wafer so its drive pin is positioned between the stop flanges. Rotate each subsequent wafer before installing so the position of its pin is staggered on the core by one stop flange. See Figure 12.

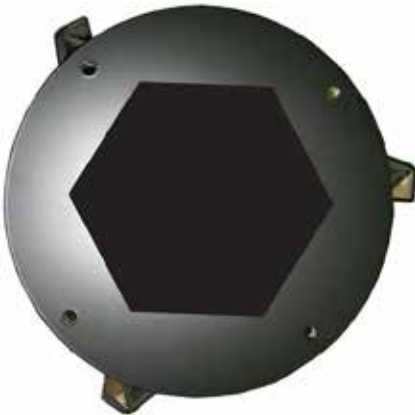

Figure 11

IMPORTANT! Proper wafer and spacer position must be followed to ensure proper balance on the core.

NOTE: The circular spacers have unconnected, overlapped ends.

3. Position the overlap of the first spacer between the stop flanges, rotated one flange ahead of the drive pin location of the last installed brush wafer. All following spacers must follow the same staggered placement pattern.

NOTE: Brush surface contact during initial operation will set all wafer drive pins up against the core stop flanges. See Figure 12.

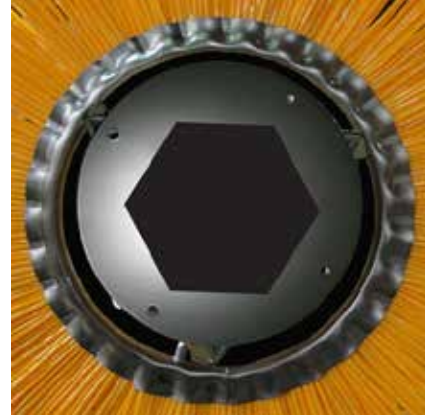

Figure 12

4. Continue stacking the core in a wafer-spacer, wafer-spacer configuration until it is full, ending with a poly brush wafer.

NOTE: The last wafer (poly) should actually extend beyond the end of the core (minimum 1/2"). The end disc compresses the spacers onto the core when tightened.

5. Install end disc on core with original hardware. See Figure 10.

Core Installation

1. Position filled core in front of the broom head. Lift the broom high enough so that core clears the hood and the brush can be rolled/pushed back into its original position. Once in place, lower broom head down to line up the center of the core hex opening with the frame opening for the hydraulic motor.
2. Slide motor hex hub into mating opening in the broom core.
3. Install motor on each side of the brush frame using original hardware. See Figure 9.
4. Before placing machine back into service, adjust and test for proper amount of brush pattern. Excessive and/or misaligned pattern can cause brush failure or premature wear. Refer to the **Setup and Adjustments** section of the manual for pattern adjustment.

STORAGE

STORAGE

- Always store the broom in a supported position, on its included stands, with the brush off the ground. If the bristles are stored in a deformed position for extended periods of time the broom will become severely out of balance.
- Store the broom in a location out of the sun and weather to prevent premature failure of plastic bristles. Bristles can become brittle when subjected to sunlight or repeated temperature changes.
- Disconnect all electrical connections between the broom and prime mover (loader/tractor) for extended storage to prevent battery drain.
- Properly clean the unit before storage and remove dirt, debris, salt, etc. to extend paint life.
- If the unit is power-washed, all lubrication points should be greased before storage.

TROUBLESHOOTING

| Trouble | Possible Cause | Remedy |
|-----------------------------------|--|--|
| Broom does not rotate. | <ol style="list-style-type: none"> 1. No hydraulic pressure/flow. 2. Hoses disconnected. 3. Hoses bent or kinked. 4. Pressure relieving too low. 5. Electric valve not functioning. | <ol style="list-style-type: none"> 1. Check prime mover hydraulic pump operation. 2. Connect hoses and fittings. 3. Remove sharp bends and kinks. 4. Adjust relief valve. 5. Check electrical connections. |
| Broom rotates in wrong direction. | <ol style="list-style-type: none"> 1. Hoses installed incorrectly. | <ol style="list-style-type: none"> 1. Switch hydraulic hose connections |
| Bristles wearing unevenly. | <ol style="list-style-type: none"> 1. Pivot frame mounting to prime mover hitch not level. 2. Pattern adjustment incorrectly set. 3. Tires on prime mover at different pressures or of different sizes. | <ol style="list-style-type: none"> 1. Adjust hitch frame/mounting frame to prime mover. Refer to the Installation section of this manual. 2. Adjust with pivot frame to brush frame actuator link. Refer to the Setup and Adjustments section of this manual. 3. Check tire pressure, sizes and rating. Adjust and/or correct as necessary. |
| Brushes wearing very quickly. | <ol style="list-style-type: none"> 1. Brush pattern too wide. | <ol style="list-style-type: none"> 1. Adjust brush pattern to be 2-4" wide. Refer to the Setup and Adjustments section of this manual. |
| Broom bounces during sweeping. | <ol style="list-style-type: none"> 1. Travel speed too fast and/or brush speed too slow. 2. Unbalanced broom core assembly. | <ol style="list-style-type: none"> 1. Adjust to find correct ground and brush speed for surface. 2. Inspect brush wafer and spacer placement on core. Refer to Maintenance section. |
| Broom sweeping poorly. | <ol style="list-style-type: none"> 1. Material is 'caked-on' or frozen. 2. Uneven sweeping surface. 3. Material is too heavy. 4. Broom rotating too slowly. 5. Prime mover moving too fast. 6. Pattern adjustment incorrectly set. | <ol style="list-style-type: none"> 1. Slow down and 'scrub' surface. 2. Increase pattern to compensate. 3. Slow down prime mover speed. 4. Increase engine speed. 5. Slow down prime mover speed. 6. Adjust with pivot frame to brush frame actuator link. Refer to the Setup and Adjustments section of this manual. |
| Broom does not lift or angle. | <ol style="list-style-type: none"> 1. No/Low hydraulic pressure/flow. 2. Electric valve not functioning. 3. System backpressure. | <ol style="list-style-type: none"> 1. Check prime mover operation. Check hydraulic oil level. Refer to Maintenance section of this manual for hydraulic system requirements. 2. Check electrical connections. 3. Check prime mover instructional manual. |
| Hydraulic pump making noise. | <ol style="list-style-type: none"> 1. Pump intake blocked. 2. Shaft seal leaking. | <ol style="list-style-type: none"> 1. Check inlet lines for obstructions. 2. Check and repair as necessary. |

SPECIFICATIONS

| | | | | | |
|------------------|--|----------------|----------------|--|--|
| Model: | TKH | | | | |
| Brush Diameter: | 32 Inches | | | | |
| Brush Length: | 8 feet (96") | 10 feet (120") | 12 feet (144") | | |
| Shipping Weight: | 1650 lbs. | 1850 lbs. | 2050 lbs. | | |
| Brush Frame: | Threaded adjustable link allows height adjustment to compensate for brush wear. Brush frame to pivot frame connection allows 10° of oscillating rotation to allow broom to follow ground irregularities. | | | | |
| Brush Drive: | Dual 18.3 c.i.d. Hydraulic Motors (for prime mover with 20 to 44 GPM) (Note: Hoses are provided from broom motors to bulkhead fittings. Customer to provide hoses and couplers to connect prime mover hydraulics to bulkhead. Does not include hydraulic valve(s) on prime mover. Brush on/off with prime mover valve unless supplied with optional Independent Hydraulic System (IHS). | | | | |
| Brush Speed: | 252 RPM Maximum | | | | |
| Brush Angle: | Maximum 30° left/right of center with provisions to hold broom in the 0° position. | | | | |
| Brush Filament: | Poly (polypropylene), Combo (Poly/Wire) Mix | | | | |
| Lift Method: | Provided by prime mover. | | | | |
| Swing Method: | Hydraulic | | | | |
| Casters: | 360° rotation of 16.5 x 6.5-8 pneumatic tires | | | | |
| Broom Hood: | Covers 140° of brush circumference | | | | |
| Mounting: | Varies by type of prime mover | | | | |
| | | | | | |

REPLACEMENT BRUSH KITS

Part Number

907-46666

907-83630

907-126982

Description

REFILL, 32 IN. X 8 FT. ,WAFER,COMBO

REFILL, 32 IN. X 10 FT. ,WAFER,COMBO

REFILL, 32 IN. X 12 FT. ,WAFER,COMBO

Warranty/Product Registration

A Warranty Registration Form must be submitted online to make warranty effective.

Warranty Start Date:

All claims must be submitted using the proper form and emailed to mbattachments@aebi-schmidt.com.

To be eligible for warranty payment the product must be registered with M-B Companies via

www.m-bco.com/warranty

M-B Companies, Inc. reserves the right to decline any claim that does not meet above requirements.

Pre-Approval Required Prior To ANY Work Being Performed.

LIMITED WARRANTY

Limited Warranty: Subject to the limitations set forth herein, M-B Companies, Inc. ("M-B") warrants its products to be free from defects in material and workmanship for a period of twelve (12) months from the date of delivery of the product to its original owner, except that the warranty is twelve (12) months solely for the following products: Truck Mounted Pavement Marking Equipment, Airport Snow Removal Products, Attachment Products, Brushes. Parts shall have a ninety (90) day warranty. This warranty is not transferable without the written consent of M-B.

Notice: M-B's obligations under this Limited Warranty are conditioned on M-B receiving, within the warranty period, written notice from Buyer specifying the nature of any alleged defect and requesting corrective action by Seller.

Remedies: M-B, at its option, will repair or replace, or provide a credit to Buyer for, defective warranted items. If requested by M-B, products or parts for which a warranty claim is made shall be returned, transportation prepaid, to M-B's factory. Buyer shall not return any product for repair, replacement or credit without M B's advance written consent.

Other Manufacturer's Warranty: On products furnished by M-B, but manufactured by any other manufacturer, the warranty of said manufacturer, if any, will be assigned to Buyer, if the said warranty is assignable. However, M-B does not represent or guarantee that such manufacturer will comply with any of the terms of the warranty of such manufacturer.

Exclusions: Any improper use, operation beyond capacity, or substitution of parts not approved by M-B, or alteration or repair by others in such a manner as in M-B's judgment materially and/or adversely affects the product shall void this warranty. This warranty does not apply to defects caused by damage or unreasonable use while in the possession of the owner, including but not limited to: failure to provide reasonable and necessary maintenance, normal wear, routine tune ups or adjustments, improper handling or accidents, operation at speed or load conditions contrary to published specifications, improper or insufficient lubrication, or improper storage.

Seller manufactures power brooms that mount to many makes and models of equipment. Seller attempts to ensure that the mounting frames fit correctly. However, the large number of tractor models, types and options currently available, compounded by frequent manufacturer design changes, may prevent Seller from supplying a frame that fits every unit correctly. Therefore, unless Buyer supplies drawing which detail the attachment points on the specific unit to which the broom will be mounted, Seller will not be responsible for the fit of the mounting frame.

The batteries, tires, rubber material, brushes and material normally consumed in operation, and major components such as engines, air compressors, and hydraulic pumps and motors are excluded from this warranty but may be covered to the extent of any warranty received by M-B from its supplier if permitted by the terms of such warranty.

Limitations of liability: M-B shall not be liable for any incidental, consequential, punitive or special damages of any kind, including, but not limited to, consequential labor costs or transportation charges in connection with the repair or replacement of defective parts, or lost time profits or expense which may have accrued because of said defect.

M-B disclaims all other warranties, whether express or implied, including but not limited to any implied warranty of merchantability or fitness for a particular purpose. This warranty is exclusive remedy of buyer. This warranty cannot be extended, broadened or changed in any respect except in writing by an authorized officer of M-B.

Notwithstanding anything in this warranty is to the contrary, in no event shall M-B's total liability hereunder exceed the purchased price of the particular product.

| | | |
|-----------|-------|-----------------------|
| DATE | BY | DESCRIPTION |
| 18-JUL-22 | JAM | REMOVED MODULAR MOUNT |
| REV | ON | |
| A | 03669 | |

| | | |
|-----------|-------|-----------------------|
| DATE | BY | DESCRIPTION |
| 18-JUL-22 | JAM | REMOVED MODULAR MOUNT |
| REV | ON | |
| A | 03669 | |

AHA-01959

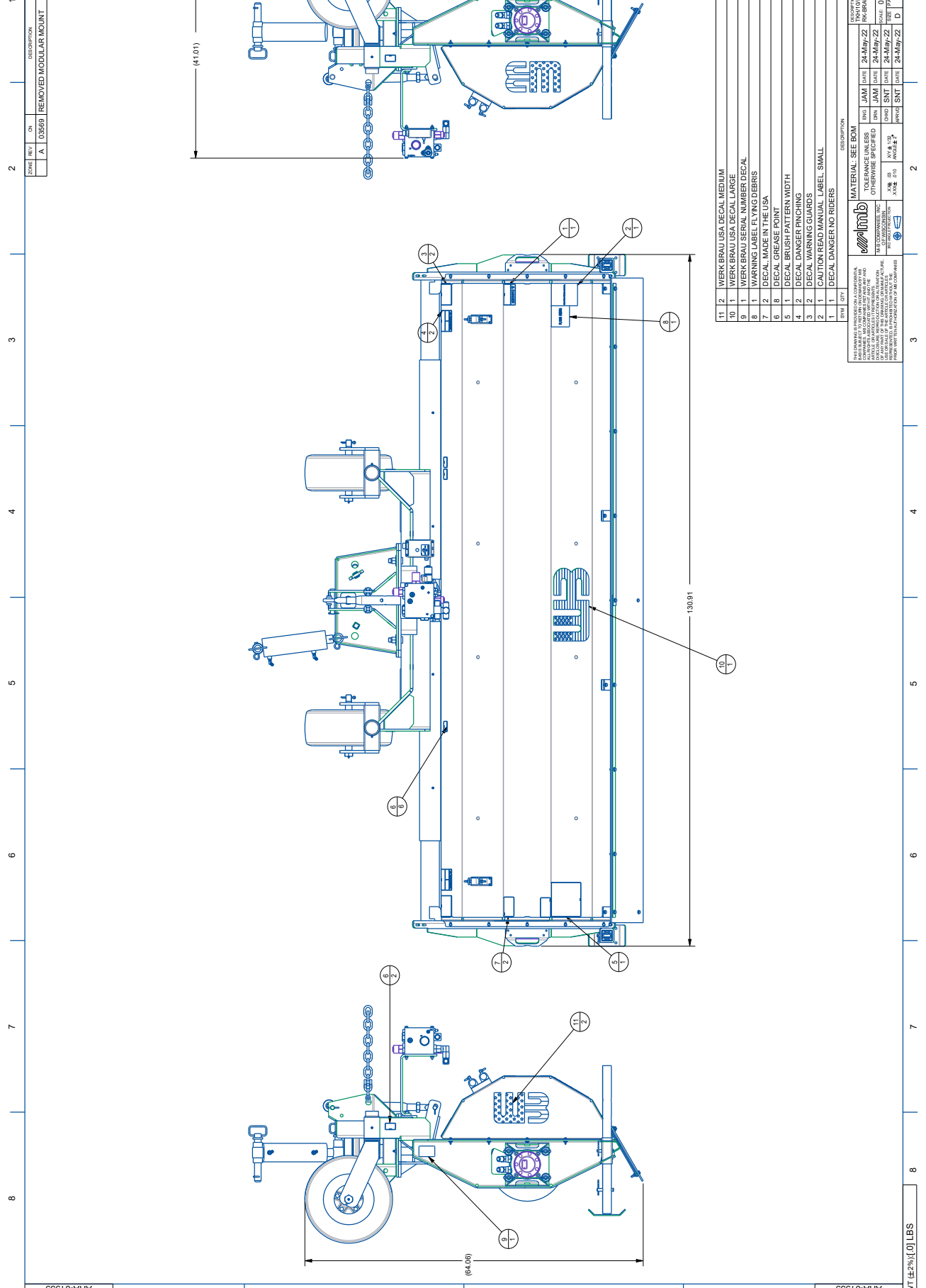

| ITEM | QTY | DESCRIPTION | SIZE | PART NUMBER |
|------|-----|---------------------------------|------|---------------|
| 11 | 2 | WERK BRAU USA DECAL MEDIUM | | B 3900-215208 |
| 10 | 1 | WERK BRAU USA DECAL LARGE | | B 3900-215207 |
| 9 | 1 | WERK BRAU SERIAL NUMBER DECAL | | A 3900-215202 |
| 8 | 1 | WARNING LABEL FLYING DEBRIS | | A 3900-188222 |
| 7 | 2 | DECAL MADE IN THE USA | | A 3900-140501 |
| 6 | 8 | DECAL GREASE POINT | | A 3900-118356 |
| 5 | 1 | DECAL BRUSH PATTERN WIDTH | | B 3900-118354 |
| 4 | 2 | DECAL DANGER PINCHING | | A 3900-118353 |
| 3 | 2 | DECAL WARNING GUARDS | | X 3900-118352 |
| 2 | 1 | CAUTION READ MANUAL LABEL SMALL | | A 3900-118351 |
| 1 | 1 | DECAL DANGER NO RIDERS | | A 3900-118349 |

| | | | |
|------------------------|-----|--------------------------------------|-----------|
| MATERIAL: SEE BOM | | TOLERANCE UNLESS OTHERWISE SPECIFIED | |
| ENG | JAM | DATE | 24-MAY-22 |
| CHK | JAM | DATE | 24-MAY-22 |
| APP | SNT | DATE | 24-MAY-22 |
| REV | SNT | DATE | 24-MAY-22 |
| SCALE: 0.120 | | SHEET 3 OF 3 | |
| PART NUMBER: AHA-01959 | | REV: A | |

| | | | |
|------------------------|-----|--------------------------------------|-----------|
| MATERIAL: SEE BOM | | TOLERANCE UNLESS OTHERWISE SPECIFIED | |
| ENG | JAM | DATE | 24-MAY-22 |
| CHK | JAM | DATE | 24-MAY-22 |
| APP | SNT | DATE | 24-MAY-22 |
| REV | SNT | DATE | 24-MAY-22 |
| SCALE: 0.120 | | SHEET 3 OF 3 | |
| PART NUMBER: AHA-01959 | | REV: A | |

AHA-01959

WT 22% (10) LBS

| | | | | | |
|------|-----|-------|---------------------------|-----|-----------|
| ZONE | REV | CN | DESCRIPTION | BY | DATE |
| | 0 | | PRODUCTION RELEASE | SJZ | 05-Feb-15 |
| | A | 12880 | SWAPPED CASTER AND WASHER | SNT | 21-Jun-17 |

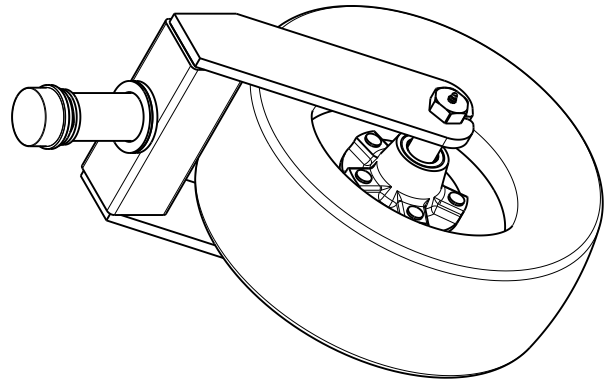

NOTES:
 1. TORQUE RECOMMENDATIONS PER WORK INSTRUCTIONS WIAS 0071
 1-14 UNF 10 FT*LBS & 50 FT*LBS
 1/2-13 WHEEL NUTS 80-90 FT*LBS
 1-1/4-7 CASTER FORK NUT 840 FT*LBS

| SYM | QTY | DESCRIPTION | SIZE | PART NUMBER |
|-----|-----|---|------|-------------|
| 14 | 1 | THRUST WASHER, HIGH LOAD, 2ID, 3OD, .13 THK | A | 603-202252 |
| 13 | 1 | CASTER FORK W.U. | B | 410-176750 |
| 12 | 1 | TOP DISK CASTER WHEEL | A | 401-202256 |
| 11 | 1 | CASTER WHEEL BOLT | A | 401-176753 |
| 10 | 1 | PIN, COTTER .25 x 2 | | 380-83943 |
| 9 | 1 | NUT, HEX, ESNA 1-1/4-7 UNC | A | 371-92009 |
| 8 | 1 | NUT, SLOTTED HEX 1-14NF | | 371-172372 |
| 7 | 1 | DUST CAP | A | 212-176932 |
| 6 | 1 | GREASE ZERK 1/4/2028 | X | 206-72100 |
| 5 | 1 | BUSHING 1 X 1-1/4 X 3-3/8 LG | A | 100-176765 |
| 4 | 1 | BUSHING 1 X 1-1/4 X 2.6 LG | A | 100-176764 |
| 3 | 1 | TIRE 16.5X6.5-8 C/6 | | 100-147334 |
| 2 | 1 | SEAL, GREASE 1.25 ID X 1.98 OD | X | 100-140383 |
| 1 | 1 | Taper Bearing Cone 2 Inch Bore | B | 100-140381 |

mb
 M&B COMPANIES, INC.
 OF WISCONSIN
 QUALITY PRODUCTION

| | | | | | |
|--------------------------------------|--------|---------|------------|--------------|------------------|
| MATERIAL | NUMBER | SEE BOM | QTY | SEE BOM | NAME |
| SEE BOM | | | | | |
| TOLERANCE UNLESS OTHERWISE SPECIFIED | | | | | |
| XX ± .03 | | | | | |
| XXX ± .010 | | | | | |
| DWN | TAK | DATE | 24-Jun-13 | SCALE | 0.250 |
| CKD | SMP | DATE | 13-Sept-13 | SIZE PART NO | |
| APP | SMP | DATE | 13-Sept-13 | REV | A |
| | | | | GROUP | TKH CASTER WHEEL |
| | | | | GROUP | |
| | | | | REV | 420-191780 |
| | | | | SHEET 1 OF 1 | A |

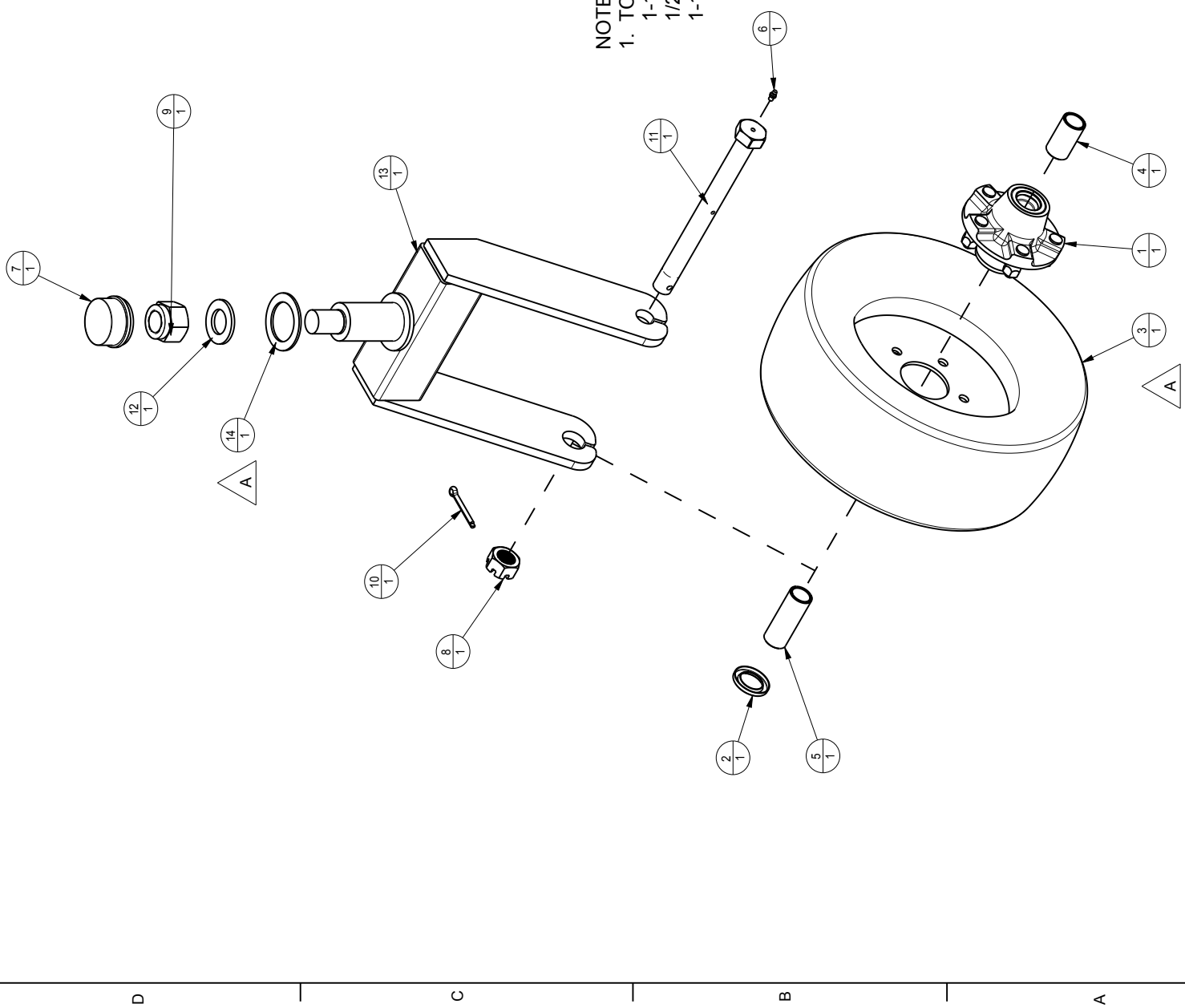

1

2

| | | | | | |
|------|-----|-------|--------------------------|----|-----------|
| ZONE | REV | CN | DESCRIPTION | BY | DATE |
| | A | 12456 | 203-190543 WAS 400-83521 | YY | 21-Apr-16 |

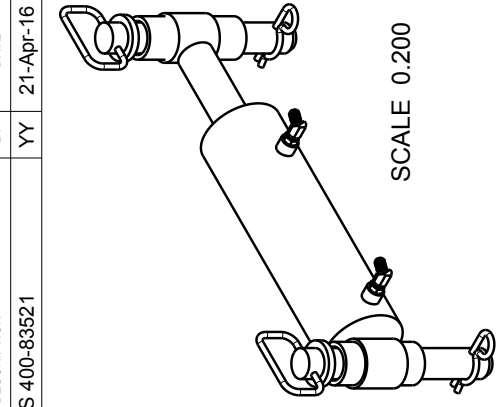

3/2

5/2

A 1/1

4/2

2/2

| SYM | QTY | DESCRIPTION | SIZE | PART NUMBER |
|-----|-----|---|------|-------------|
| 5 | 2 | SPACER, CYLINDER 1.38 LONG | A | 400-75978 |
| 4 | 2 | SPACER, CYLINDER .938 LONG | A | 400-75977 |
| 3 | 2 | PIN, HITCH 1 1/4 X 8 | A | 383-132568 |
| 2 | 2 | ELBOW 45, -4 JICM X -4 ORBM | | 211-190703 |
| 1 | 1 | HYD CYLINDER 3 INCH, BORE 7 INCH STROKE | B | 203-190543 |



M.B. COMPANIES, INC.
OF WISCONSIN
3RD ANGLE PROJECTION

| MATERIAL | NUMBER | QTY | NAME |
|----------|--------|-----|---------|
| | | | SEE BOM |

HYD SWING OPTION,
FOR VALVE BLOCK, TKH

| | | | | |
|--------------------------------------|-----|-----|-----------|--------------------------|
| TOLERANCE UNLESS OTHERWISE SPECIFIED | DWN | YY | DATE | SHEET 1 OF 1 |
| XX ± .03 | CKD | SMF | 01-May-14 | SCALE: 0.300 |
| XXX ± .010 | APP | SMF | 01-May-14 | SIZE PART NO. 432-190702 |
| | | | | REV A |

1

2

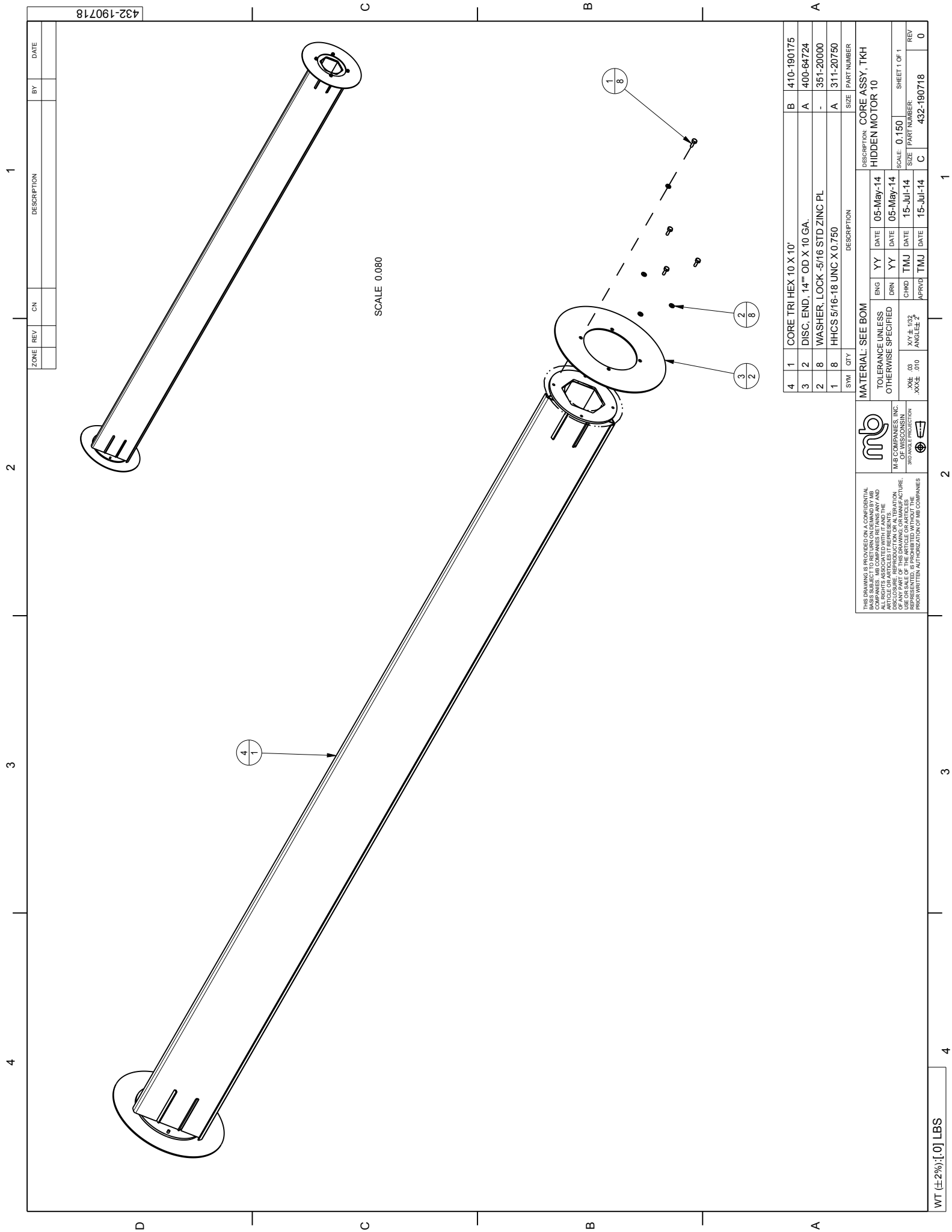

SCALE 0.080

432-190718

| | | | | | |
|------|-----|----|-------------|----|------|
| ZONE | REV | CN | DESCRIPTION | BY | DATE |
| | | | | | |

| | | | | |
|---|---|--------------------------------|-----|------------------|
| 4 | 1 | CORE TRI HEX 10 X 10' | B | 410-190175 |
| 3 | 2 | DISC, END, 14" OD X 10 GA. | A | 400-64724 |
| 2 | 8 | WASHER, LOCK -5/16 STD ZINC PL | - | 351-20000 |
| 1 | 8 | HHCS 5/16-18 UNC X 0.750 | A | 311-20750 |
| | | SYM | QTY | DESCRIPTION |
| | | | | SIZE PART NUMBER |

mb
M-B COMPANIES, INC.
3RD FLOOR
OF WISCONSIN
3RD FLOOR

THIS DRAWING IS PROVIDED ON A CONFIDENTIAL BASIS TO THE PURCHASER AND IS THE PROPERTY OF M-B COMPANIES, INC. ALL RIGHTS ASSOCIATED WITH IT AND THE INFORMATION CONTAINED HEREIN ARE RESERVED. DISCLOSURE, REPRODUCTION OR ALTERATION OF THIS DRAWING WITHOUT THE WRITTEN PERMISSION OF M-B COMPANIES, INC. IS PROHIBITED. WITHOUT LIMITATION, THE PURCHASER SHALL NOT REPRODUCE OR TRANSMIT THIS DRAWING TO ANY OTHER PARTY.

MATERIAL: SEE BOM
TOLERANCE UNLESS OTHERWISE SPECIFIED

| | | | |
|-------|-----|------|-----------|
| ENG | YY | DATE | 05-May-14 |
| DRN | YY | DATE | 05-May-14 |
| CHKD | TMJ | DATE | 15-Jul-14 |
| APPRV | TMJ | DATE | 15-Jul-14 |

SCALE: 0.150
SHEET 1 OF 1
REV 0

WT (±2%): [0] LBS

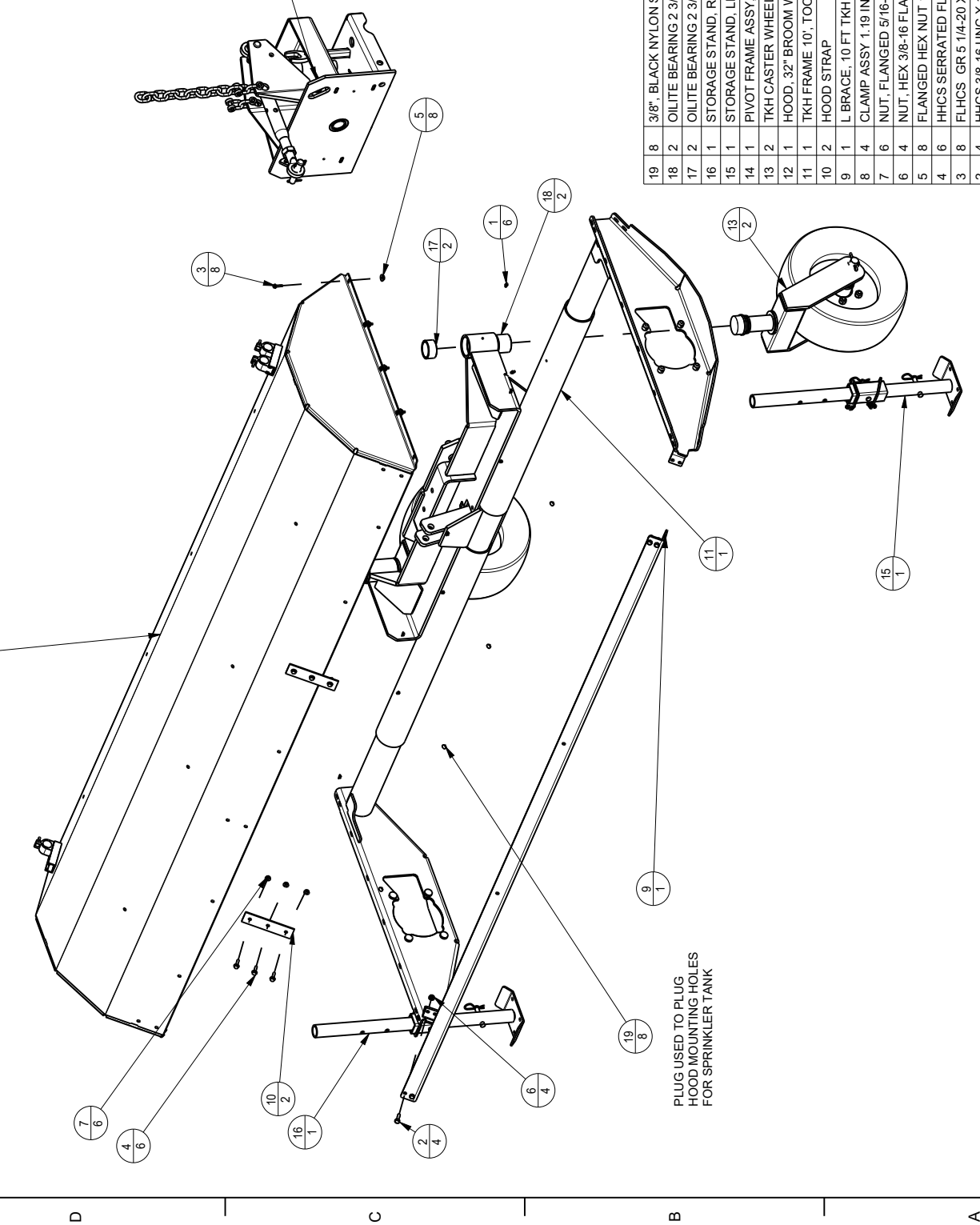
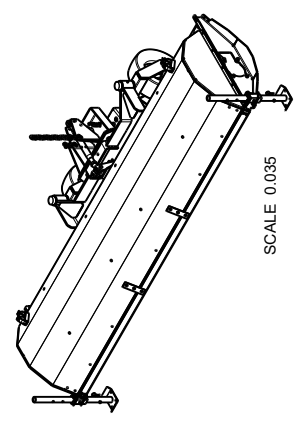

PLUG USED TO PLUG HOOD MOUNTING HOLES FOR SPRINKLER TANK

| SYM | QTY | DESCRIPTION | SIZE | PART NUMBER |
|-----|-----|--|------|-------------|
| 19 | 8 | 3/8" BLACK NYLON SNAP-IN PLUG | X | 711-215228 |
| 18 | 2 | OILITE BEARING 2 3/8 X 2 X 1 3/4 LG SAE 863 | A | 603-201155 |
| 17 | 2 | OILITE BEARING 2 3/8 X 2 X 1 1/8 LG SAE 863 | B | 603-201154 |
| 16 | 1 | STORAGE STAND, RH TKH | D | 432-203382 |
| 15 | 1 | STORAGE STAND, LH TKH | D | 432-203381 |
| 14 | 1 | PIVOT FRAME ASSY, TKH, BLK | C | 420-215230 |
| 13 | 2 | TKH CASTER WHEEL GROUP | C | 420-191780 |
| 12 | 1 | HOOD, 32" BROOM WITH DUAL TANK HOLES, 10', BLACK | B | 410-215223 |
| 11 | 1 | TKH FRAME 10', TOOLLESS, BLACK | D | 410-215222 |
| 10 | 2 | HOOD STRAP | A | 401-215238 |
| 9 | 1 | L BRACE, 10 FT TKH FRAME, BLACK | B | 401-215226 |
| 8 | 4 | CLAMP ASSY 1.19 INCH | A | 387-126788 |
| 7 | 6 | NUT, FLANGED 5/16-18 PLATED LOCKING | X | 371-92059 |
| 6 | 4 | NUT, HEX 3/8-16 FLANGE LOCKING | X | 371-92057 |
| 5 | 8 | FLANGED HEX NUT 1/4-20 | A | 371-190155 |
| 4 | 6 | HHCS SERRATED FLANGE 5/16-18 X 1 | X | 370-190649 |
| 3 | 8 | FLHCS GR 5 1/4-20 X 1 | X | 370-190154 |
| 2 | 4 | HHCS 3/8-16 UNC X 1.000 | A | 311-31000 |
| 1 | 6 | GREASE ZERK 1/4-28 | X | 206-72100 |

MATERIAL: SEE BOM

TOLERANCE UNLESS OTHERWISE SPECIFIED

| | | | |
|-------|-----|------|-----------|
| ENG | JAM | DATE | 24-May-22 |
| DRN | SMT | DATE | 24-May-22 |
| CHKD | SNT | DATE | 24-May-22 |
| APPRD | SNT | DATE | 24-May-22 |

SCALE: 0.100

SHEET 1 OF 1

REV 0

432-215229

WT (±2%): [0] LBS

| | | | | | |
|------|-----|----|-------------|----|------|
| ZONE | REV | CN | DESCRIPTION | BY | DATE |
| | | | | | |

NOTE: IF DRIVE TUBES ARE TOO SHORT, URETHANE MAY BULGE AND HAMPER FIT INTO CORE HEXAGONAL OPENING

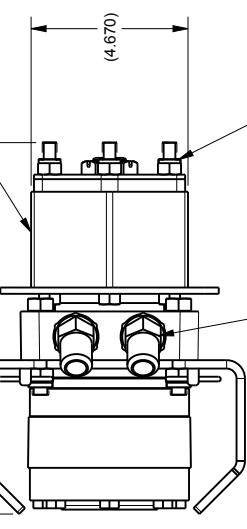

TORQUE TO SIZE GR8 SPECS 70 FT-LBS

NOTE: INDEX FITTINGS AS INDICATED

NOTE: DO NOT LUBRICATE SHAFT DRY FIT ONLY

Torque to 271 Nm [200 lbf-ft] plus torque required to align slotted nut with shaft cross hole not to exceed 400 Nm [295 lbf-ft]. Lubricate nut face and shaft threads.

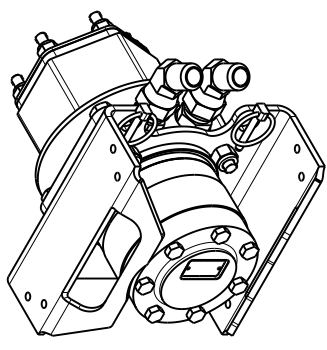

SCALE 0.300

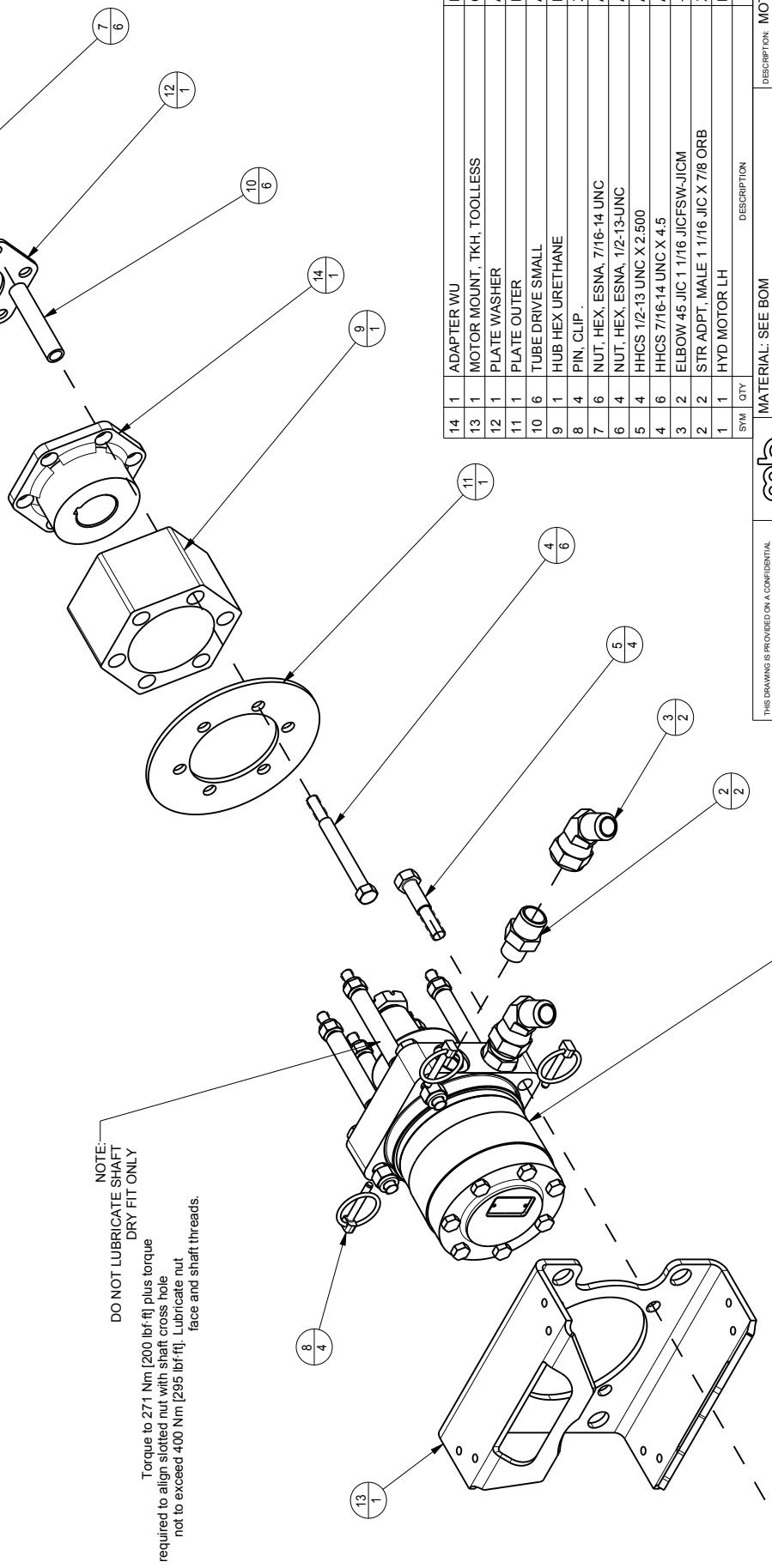

| SYM | QTY | DESCRIPTION | SIZE | PART NUMBER |
|-----|-----|-------------------------------------|------|-------------|
| B | 1 | ADAPTER WU | | 410-176936 |
| C | 1 | MOTOR MOUNT, TKH, TOOLLESS | | 401-203150 |
| A | 1 | PLATE WASHER | | 401-190048 |
| B | 1 | PLATE OUTER | | 401-176926 |
| A | 1 | TUBE DRIVE SMALL | | 401-176924 |
| B | 1 | HUB HEX URETHANE | | 401-176923 |
| X | 4 | PIN, CLIP | | 380-90475 |
| A | 6 | NUT, HEX, ESNA, 7/16-14 UNC | | 371-82080 |
| A | 4 | NUT, HEX, ESNA, 1/2-13 UNC | | 371-81417 |
| A | 4 | HHCS 1/2-13 UNC X 2.500 | | 311-52500 |
| A | 4 | HHCS 7/16-14 UNC X 4.5 | | 311-190049 |
| X | 2 | ELBOW 45 JIC 1.1/16 JICFSW-JICM | | 211-83296 |
| X | 2 | STR ADPT, MALE 1.1/16 JIC X 7/8 ORB | | 211-51813 |
| B | 1 | HYD MOTOR LH | | 201-176962 |

| | | | | | | | |
|--------------------------------------|-----|-------|-----------|--|-----|------|-----------|
| MATERIAL: SEE BOM | | | | DESCRIPTION: MOTOR ASSY, TKH, STD FLOW, LH, TOOLLESS | | | |
| ENG | SNT | DATE | 05-Dec-18 | CHD | TMJ | DATE | 05-Dec-18 |
| TOLERANCE UNLESS OTHERWISE SPECIFIED | | | | CHD | TMJ | DATE | 23-Jan-19 |
| XXL | 03 | XXS | 4-103 | APPRV | TMJ | DATE | 23-Jan-19 |
| XXXL | 010 | ANGLE | 2 | REV | | | 0 |
| SCALE: 0.350 | | | | SHEET 1 OF 1 | | | |
| SIZE PART NUMBER: C 432-203122 | | | | REV PART NUMBER: C 432-203122 | | | |

THIS DRAWING IS PROVIDED ON A CONFIDENTIAL BASIS AND IS THE PROPERTY OF M-B COMPANIES, INC. ALL RIGHTS ASSOCIATED WITH IT AND THE INFORMATION CONTAINED HEREIN ARE RESERVED. REPRODUCTION OR ALTERATION OF THIS DRAWING WITHOUT THE WRITTEN PERMISSION OF M-B COMPANIES, INC. IS PROHIBITED. USE OR SALE OF THIS DRAWING OR ANY INFORMATION CONTAINED HEREIN FOR THE PURPOSES OF REPRODUCING OR MANUFACTURING ANY PARTS OR ASSEMBLIES OF THE COMPANIES REPRESENTED IS PROHIBITED WITHOUT THE WRITTEN PERMISSION OF THE COMPANIES REPRESENTED.

WT (±2%): [0] LBS

4 3 2 1

| | | | | |
|------|-----|----|----|------|
| ZONE | REV | CN | BY | DATE |
| | | | | |

IF DRIVE TUBES ARE TOO SHORT, URETHANE MAY BULGE AND HAMPER FIT INTO CORE HEXAGONAL OPENING

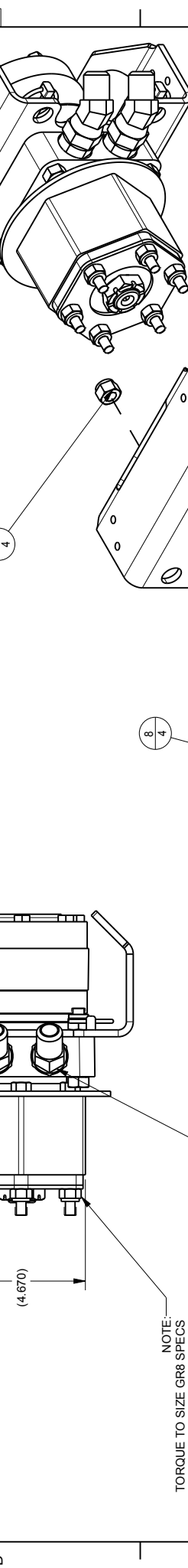

NOTE: TORQUE TO SIZE GR8 SPECS 70 FT-LBS

INDEX AS SHOWN TO CLEAR FRAME OPENING

NOTE: DO NOT LUBRICATE SHAFT DRY FIT ONLY

Torque to 271 Nm [200 lbf-ft] plus torque required to align slotted nut with shaft cross hole not to exceed 400 Nm [295 lbf-ft]. Lubricate nut face and shaft threads.



| SYM | QTY | DESCRIPTION | SIZE | PART NUMBER |
|-----|-----|-------------------------------------|------|-------------|
| B | 1 | ADAPTER WU | | 410-176936 |
| C | 1 | MOTOR MOUNT, TKH, TOOLLESS | | 401-203150 |
| A | 1 | PLATE WASHER | | 401-190048 |
| B | 1 | PLATE OUTER | | 401-176926 |
| A | 1 | TUBE DRIVE SMALL | | 401-176924 |
| B | 1 | HUB HEX URETHANE | | 401-176923 |
| X | 4 | PIN, CLIP | | 380-90475 |
| A | 6 | NUT, HEX, ESNA, 7/16-14 UNC | | 371-82080 |
| A | 4 | NUT, HEX, ESNA, 1/2-13-UNC | | 371-81417 |
| A | 4 | HHCS 1/2-13 UNC X 2.500 | | 311-52500 |
| A | 6 | HHCS 7/16-14 UNC X 4.5 | | 311-190049 |
| X | 2 | ELBOW 45 JIC 1 1/16 JICFSW-JICM | | 211-83296 |
| X | 2 | STR ADPT, MALE 1 1/16 JIC X 7/8 ORB | | 211-51813 |
| B | 1 | HYD MOTOR RH | | 201-176963 |

MATERIAL: SEE BOM

TOLERANCE UNLESS OTHERWISE SPECIFIED

SCALE: 0.375

DESCRIPTION: MOTOR ASSY, TKH, STD FLOW, RH, TOOLLESS

DATE: 05-Dec-18

DATE: 05-Dec-18

DATE: 20-May-19

DATE: 20-May-19

REV: 0

WT (±2%): [0] LBS

1 2 3 4

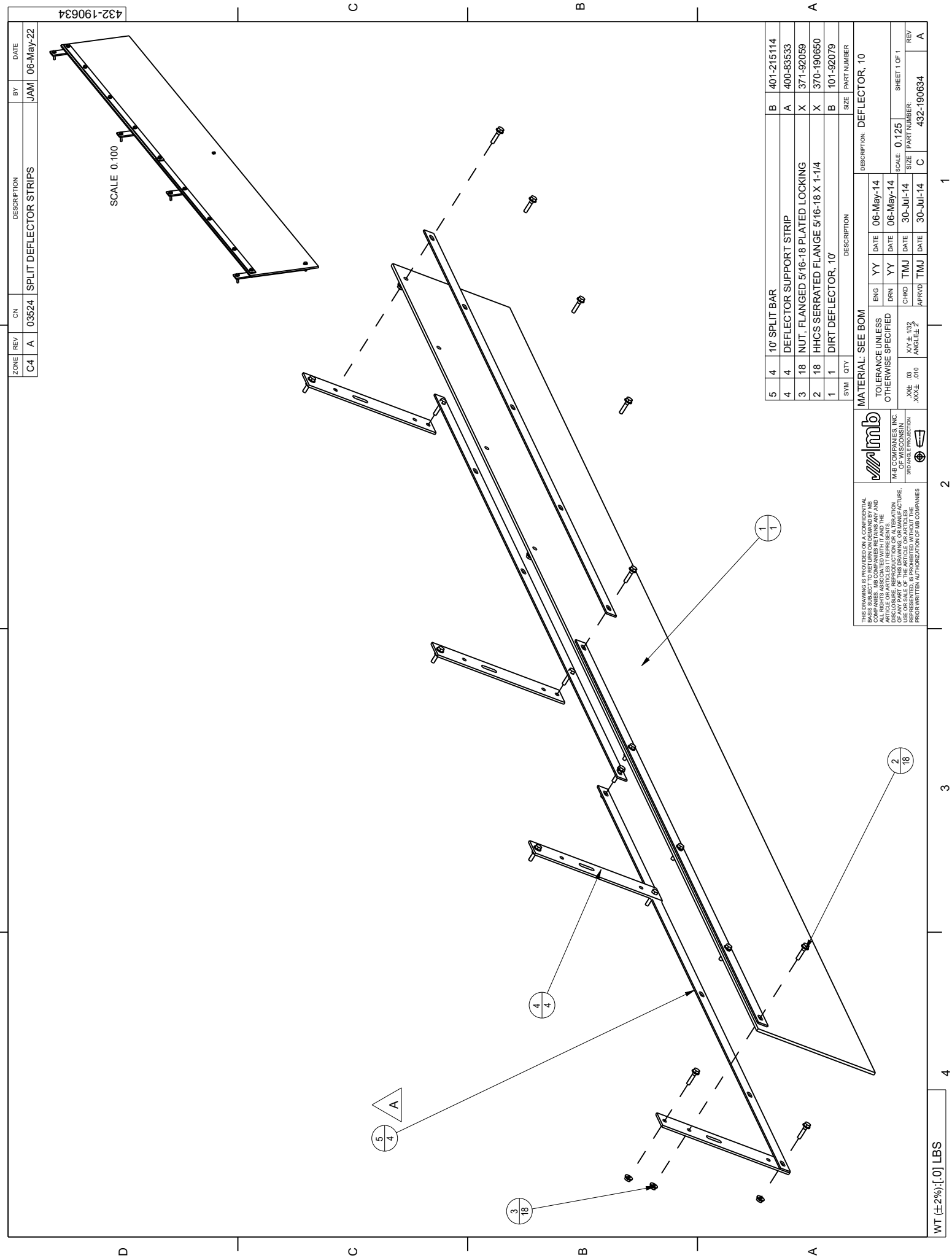

SCALE 0.100

| ZONE | REV | CN | DESCRIPTION | BY | DATE |
|------|-----|-------|------------------------|-----|-----------|
| C4 | A | 03524 | SPLIT DEFLECTOR STRIPS | JAM | 06-May-22 |

432-190634

| | | | | | |
|---|----|----|--------------------------------------|---|------------|
| 5 | 4 | 10 | SPLIT BAR | B | 401-215114 |
| 4 | 4 | | DEFLECTOR SUPPORT STRIP | A | 400-83533 |
| 3 | 18 | | NUT, FLANGED 5/16-18 PLATED LOCKING | X | 371-92059 |
| 2 | 18 | | HHCS SERRATED FLANGE 5/16-18 X 1-1/4 | X | 370-190650 |
| 1 | 1 | | DIRT DEFLECTOR, 10' | B | 101-92079 |

| | | | | | |
|--------------------------------------|----|--------|-----|-----|--------|
| MATERIAL: SEE BOM | | | | | |
| TOLERANCE UNLESS OTHERWISE SPECIFIED | | | | | |
| ENG | YY | DATE | CHD | TMJ | DATE |
| | 06 | May-14 | | 30 | Jul-14 |
| APPROV | | | | | |
| SCALE: 0.125 | | | | | |
| SIZE (PART NUMBER) | | | | | |
| C 432-190634 | | | | | |
| REV A | | | | | |

THIS DRAWING IS PROVIDED ON A CONFIDENTIAL BASIS AND IS THE PROPERTY OF M-B COMPANIES, INC. ALL RIGHTS ASSOCIATED WITH IT AND THE INFORMATION CONTAINED HEREIN ARE RESERVED. DISCLOSURE, REPRODUCTION OR ALTERATION OF THIS DRAWING WITHOUT THE WRITTEN PERMISSION OF M-B COMPANIES, INC. IS PROHIBITED. USE OR SALE OF THIS ARTICLE OR ARTICLES REPRESENTED IS PROHIBITED WITHOUT THE WRITTEN PERMISSION OF M-B COMPANIES, INC.

WT (±2%): [0] LBS

| | | | | | |
|------|-----|----|-------------|----|------|
| ZONE | REV | CN | DESCRIPTION | BY | DATE |
| | | | | | |

SV1
SPOOL 202-160975
COILS 202-169553
SPACER 202-127978-14

RV3
202-215348

EP2
202-190003

CV1
202-169569

CV2
202-190004

RV2
202-215347

EP3
202-190003

RV1
202-215347

EP1
202-190003

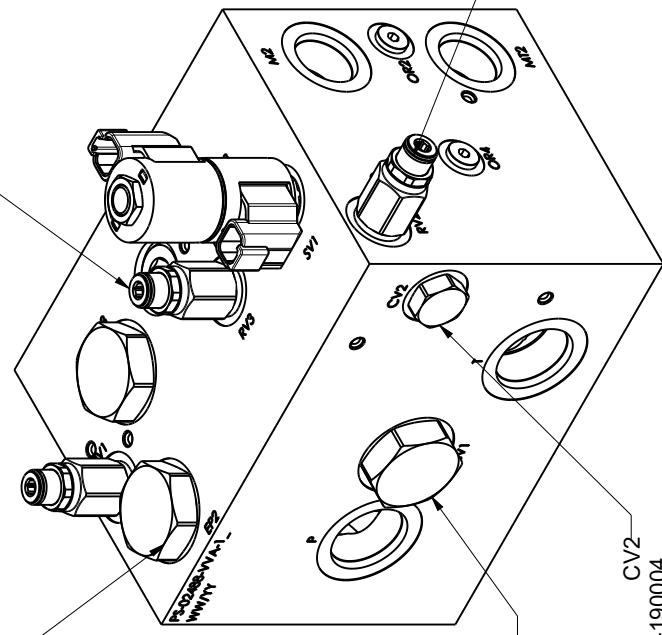

FRONT

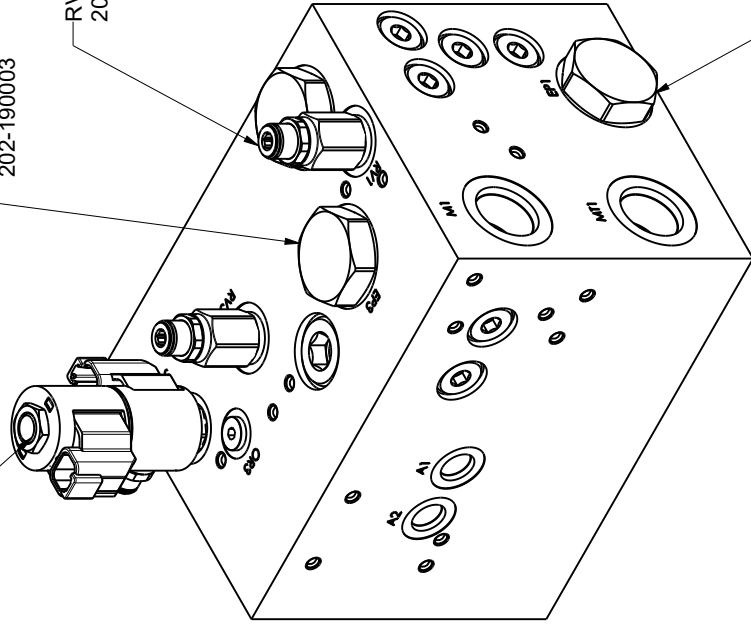

BACK

THIS DRAWING IS PROVIDED ON A CONFIDENTIAL BASIS AND IS THE PROPERTY OF M-B COMPANIES, INC. ALL RIGHTS ASSOCIATED WITH IT AND THE INFORMATION CONTAINED HEREIN ARE RESERVED. DISCLOSURE, REPRODUCTION OR ALTERATION OF THIS DRAWING IS PROHIBITED WITHOUT THE WRITTEN PERMISSION OF M-B COMPANIES, INC.

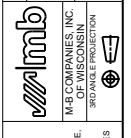

MATERIAL: PURCHASED
TOLERANCE UNLESS OTHERWISE SPECIFIED
XXS .05
XXL .10
XXE .010

| SYM | QTY | DESCRIPTION | SIZE | PART NUMBER |
|-------|-----|-------------|------|--|
| ENG | | 05-AUG-22 | | TKH VALVE ASSY, 40GPM, 24V ELE. SYS., MACHINE REVERSED |
| DRN | | 05-AUG-22 | | SCALE: 0.625 |
| CHKD | | JAM | | SHEET 1 OF 1 |
| APPRV | | JAM | | REV 0 |

WT (±2%): [0] LBS

1

1 2 3 4

| | | | | | |
|------|-------|----|-------------------------------|-----|-----------|
| ZONE | REV | CN | DESCRIPTION | BY | DATE |
| A | 03574 | | SWAPPED MOUNTING AND FITTINGS | SNT | 03-Aug-22 |

432-215232

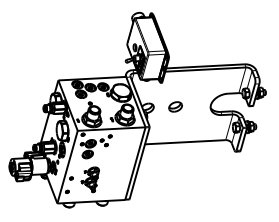

SCALE 0.125

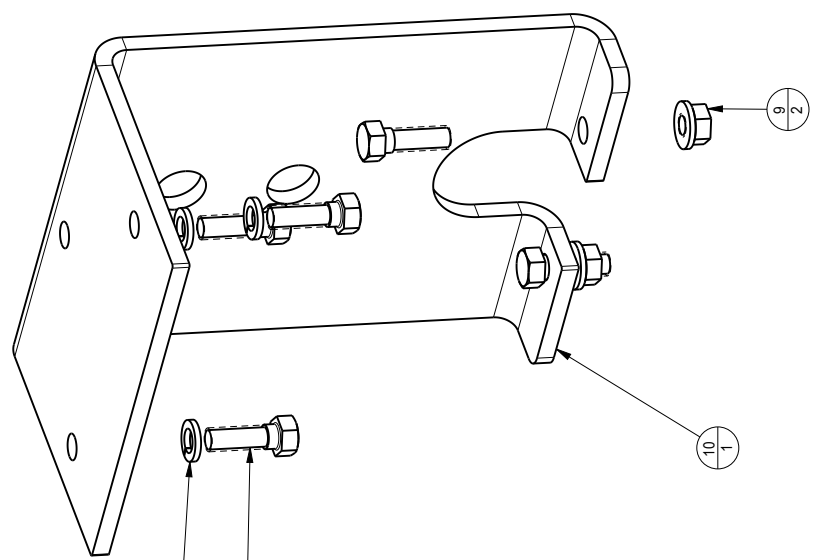
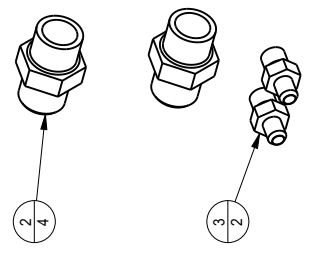
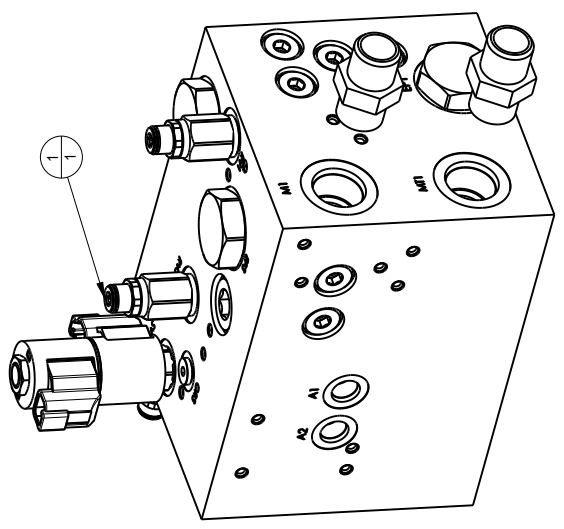
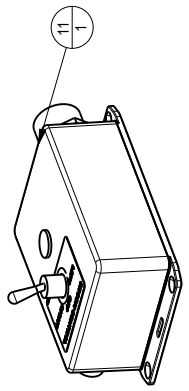

| SYM | QTY | DESCRIPTION | SIZE | PART NUMBER |
|-----|-----|---|------|----------------|
| 11 | 1 | HARNES, LONG LARGE LOADER WITH BLINK AUX OPT. | B | 703-202409 |
| 10 | 1 | TKH VALVE MOUNTING WKBR | B | 401-215343 |
| 9 | 2 | NUT, SERRATED 1/2-13 PLATED | A | 371-920586 |
| 8 | 3 | WASHER, LOCK -1/2 YLW ZINC PL | - | 351-50000 |
| 7 | 5 | HHCS 1/2-13 UNC X 1.500 | A | 311-51500 |
| 6 | 1 | HOSE ASSY, 1/4 inX48in OAL, -4JICFSW X -4JICFSW 90, 3000PSI | B | 213-203079 |
| 5 | 1 | HOSE ASSY, 1/4" X 58" OAL, -4JICFSW X -4JICFSW 90 | B | 213-190706 |
| 4 | 4 | HOSE ASSY, 3/4" X 86" OAL, -12JICFSW X -12JICFSW-45 DEG | B | 213-190485 |
| 3 | 2 | STR ADPT, MALE 7/16 JIC X 9/16 ORB | X | 211-72412 |
| 2 | 4 | STR ADPT, MALE 1 1/16 X 1 1/16 | - | 211-51800 |
| 1 | 1 | VALVE, TKH, WERK BRAU 24V | | 202-215196_IGS |

| ENG | JAM | DATE | DESCRIPTION |
|-----|-----|-----------|--|
| | | 24-May-22 | TKH VALVE ASSY, DESCRIPTION, UCLY SUS, MACHINE REVERSED. |
| | | 24-May-22 | SCALE: 0.500 |
| | | 24-May-22 | SHEET 1 OF 2 |
| | | 24-May-22 | REV |

MATERIAL: SEE BOM

TOLERANCE UNLESS OTHERWISE SPECIFIED

M-B COMPANIES, INC.
OF WISCONSIN
3RD FLOOR
1000 WISCONSIN ST
MILWAUKEE, WI 53212

XX4 .03
XXE .010

ANGLE 2°

THIS DRAWING IS PROVIDED ON A CONFIDENTIAL BASIS AND IS THE PROPERTY OF M-B COMPANIES, INC. ALL RIGHTS ASSOCIATED WITH IT AND THE INFORMATION CONTAINED HEREIN ARE RESERVED. REPRODUCTION OR ALTERATION OF THIS DRAWING WITHOUT THE WRITTEN PERMISSION OF M-B COMPANIES, INC. IS PROHIBITED. USE OR SALE OF THIS DRAWING OR ARTICLES REPRESENTED IS PROHIBITED WITHOUT THE WRITTEN PERMISSION OF M-B COMPANIES, INC.

WT (±2%): 67 LBS

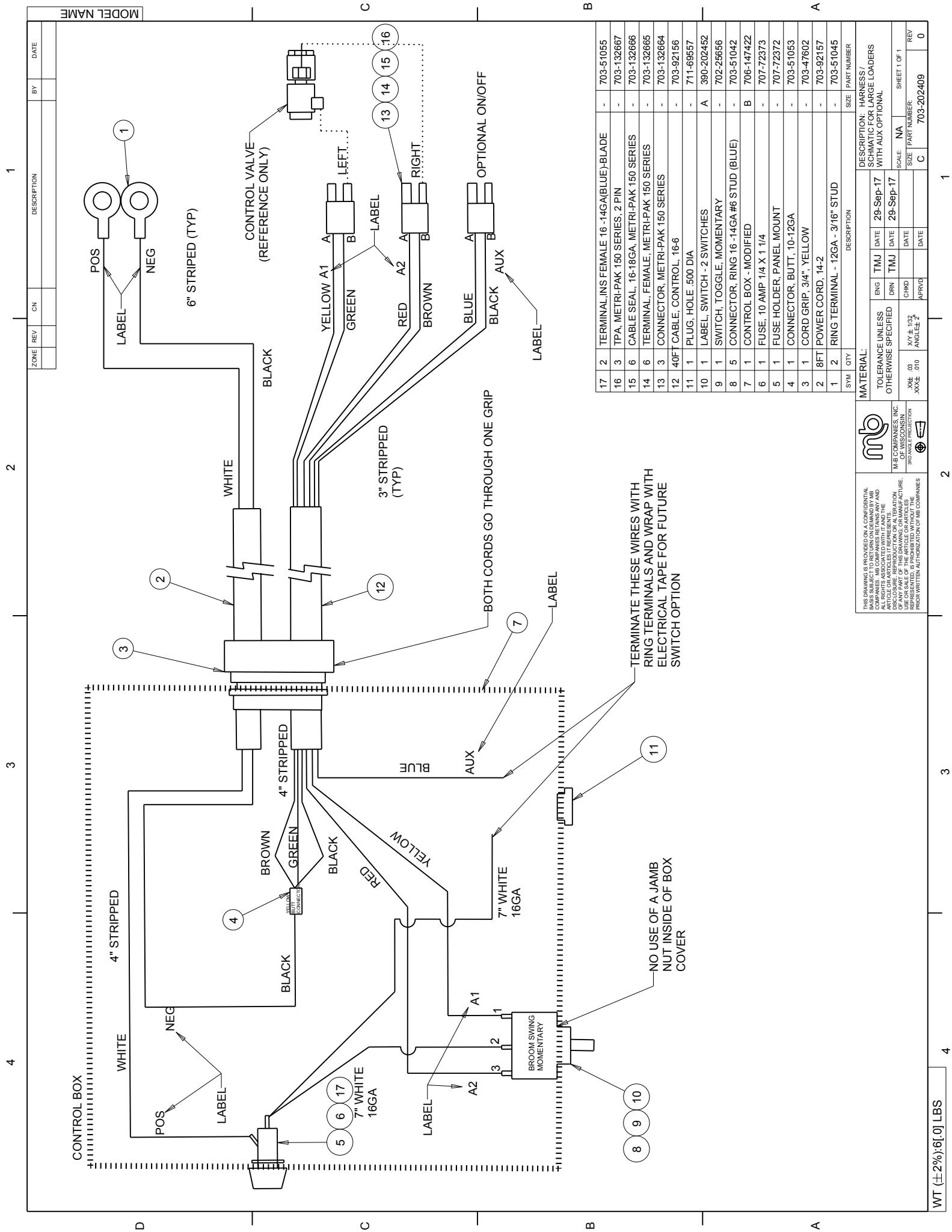

| SYM | QTY | DESCRIPTION | SIZE | PART NUMBER |
|-----|-----|---|------|-------------|
| 17 | 2 | TERMINAL-INS FEMALE 16-14GA(BLUE)-BLADE | | 703-51055 |
| 16 | 3 | TPA, METRI-PAK 150 SERIES, 2 PIN | | 703-132667 |
| 15 | 6 | CABLE SEAL, 16-18GA, METRI-PAK 150 SERIES | | 703-132666 |
| 14 | 6 | TERMINAL, FEMALE, METRI-PAK 150 SERIES | | 703-132665 |
| 13 | 3 | CONNECTOR, METRI-PAK 150 SERIES | | 703-132664 |
| 12 | 1 | 40FT CABLE, CONTROL, 16-6 | | 703-92156 |
| 11 | 1 | PLUG, HOLE .500 DIA | | 711-69557 |
| 10 | 1 | LABEL, SWITCH - 2 SWITCHES | A | 390-202452 |
| 9 | 1 | SWITCH, TOGGLE, MOMENTARY | | 702-28656 |
| 8 | 5 | CONNECTOR, RING 16-14GA #6 STUD (BLUE) | | 703-51042 |
| 7 | 1 | CONTROL BOX - MODIFIED | B | 706-147422 |
| 6 | 1 | FUSE, 10 AMP 1/4 X 1 1/4 | | 707-72373 |
| 5 | 1 | FUSE HOLDER, PANEL MOUNT | | 707-72372 |
| 4 | 1 | CONNECTOR, BUTT, 10-12GA | | 703-51053 |
| 3 | 1 | CORD GRIP, 3/4", YELLOW | | 703-47602 |
| 2 | 8FT | POWER CORD, 14-2 | | 703-92157 |
| 1 | 2 | RING TERMINAL - 12GA - 3/16" STUD | | 703-51045 |

THIS DRAWING IS PROVIDED ON A CONFIDENTIAL BASIS TO THE CUSTOMER AND IS THE PROPERTY OF M-B COMPANIES, INC. ALL RIGHTS ASSOCIATED WITH IT AND THE INFORMATION CONTAINED HEREIN ARE RESERVED. DISCLOSURE, REPRODUCTION OR ALTERATION OF THIS DRAWING IS STRICTLY PROHIBITED. USE OR SALE OF THIS ARTICLE OR ARTICLES REPRESENTED, IS PROHIBITED WITHOUT THE WRITTEN PERMISSION OF M-B COMPANIES, INC.

M-B COMPANIES, INC.
3RD FLOOR
OF WISCONSIN
300 W. WISCONSIN

MATERIAL:

| DESCRIPTION | DATE | DATE | DATE | DATE |
|--------------------------------------|-----------|------|------|------|
| TOLERANCE UNLESS OTHERWISE SPECIFIED | 29-Sep-17 | | | |
| SCALE | NA | | | |
| SIZE | NA | | | |

REV SHEET 1 OF 1

703-202409 0

MODEL NAME

ZONE REV CN BY DATE

DESCRIPTION

1 2 3 4

A B C D

WT (±2%):6f.0j LBS