

WERK-BRAU CO., INC. PRODUCT AND INSTALLATION MANUAL

D-TILT COUPLER

(TD-035/055/080/140/180/240/350)



Serial No:

Model No:

Date Manufactured:



PROUDLY MANUFACTURED IN FINDLAY, OH
Werk-Brau.com

Table of Contents

Introduction

Table of Contents.....	2
Safety Statements and Precautions.....	3
Product Overview	7
Operation Technology.....	7
General Safety Guidelines.....	8

Installation and Maintenance

Hydraulic Requirements and Plumbing	10
Auxiliary Ports Orientation	11
Port Locations.....	12
Coupler Welding & Rotary Union Lubrication	13
Flushing & Air Purging Procedure.....	14
Maintenance	19
Troubleshooting Guide	20

Drawing

TD-035/350 Assembly Drawing	21
Parts List	27

Disassembly

Product Inspection	24
Removal of Coupler	24
Disassembly of D-Tilt	25

Assembly

Coupler Removal and Disassembly.....	28
Shims Replacement	32
Dry Assembly	29
Assembly of D-Tilt	34
Fastener Torque Specifications	39
D-Tilt Specifications	40

Post Assembly

Testing and Greasing	41
----------------------------	----

SAFETY STATEMENT GUIDE

**DANGER**

Danger tags are used in major hazard situations where an immediate hazard presents a threat of death or serious injury to operator and anyone about.

**WARNING**

Warning tags are used to represent a hazard level between “Caution” and “Danger”, instead of the required “Caution” tag, provided that they have a signal word of “Warning,” an appropriate major message.

**CAUTION**

Caution tags are used in minor hazard situations where a non-immediate or potential hazard or unsafe practice presents a lesser threat of injury.

**NOTICE**

A notice label is used where equipment or property damage could result if the instructions are not followed properly.



This symbol by itself or used with a safety signal word throughout this manual is used to call your attention to instructions involving your personal safety or the safety of others. Failure to follow these instructions can result in injury or death.

GENERAL SAFETY PRECAUTIONS

⚠ DANGER

READ MANUAL PRIOR TO INSTALLATION

Improper installation, operation, or maintenance of this equipment could result in serious injury or death. Operators and maintenance personnel should read this manual as well as all manuals related to this equipment and the operating machine thoroughly before beginning installation, operation, or maintenance. FOLLOW ALL SAFETY INSTRUCTIONS IN THIS MANUAL AND THE OPERATING MACHINES MANUAL.

⚠ WARNING

READ AND UNDERSTAND ALL SAFETY STATEMENTS

Read all safety decals and safety statements in all manuals prior to operating or working on this equipment. Know and obey all OSHA regulations, local laws and other professional guidelines for your operation. Know and follow good work practices when assembling, maintaining, repairing, mounting, removing or operating this equipment.

⚠ DANGER

KNOW YOUR EQUIPMENT

Know your equipment's capabilities, dimensions and operations before operating. Visually inspect your equipment before you start, and never operate equipment that is not in proper working order with all safety devices intact. Check all hardware to assure it is tight. Make certain that all locking pins, latches, and connection devices are properly installed and secured. Remove and replace any damaged, fatigued or excessively worn parts. Make certain all safety decals are in place and are legible. Keep decals clean, and replace them if they become worn and hard to read.

NOTICE

PROTECT AGAINST FLYING DEBRIS

Always wear proper safety glasses, goggles with a face shield when driving pins in or out or when any operation causes dust, flying debris, or any other hazardous material.

⚠ WARNING

LOWER OR SUPPORT RAISED EQUIPMENT

Do not work under raised booms without supporting them. Do not use support material made of concrete blocks, logs, buckets, barrels or any other material that could suddenly collapse or shift positions. Make sure support material is solid, not decayed, warped, twisted, or tapered. Lower the boom(s) to ground level or onto block(s). Lower the boom(s) and attachment(s) to the ground before leaving the cab or operator's station.

GENERAL SAFETY PRECAUTIONS

WARNING

USE CARE WITH HYDRAULIC FLUID PRESSURE

Hydraulic fluid under pressure can penetrate the skin and cause serious injury or death. Hydraulic leaks under pressure may not be visible. Before connecting or disconnecting hydraulic hoses, read your operating machines operator's manual for detailed instructions on connecting and disconnecting hydraulic hoses or fittings.

- Keep unprotected body parts, such as face, eyes, and arms as far away as possible from a suspected leak. Flesh injected with hydraulic fluid may develop gangrene or other permanent disabilities. Wear safety glasses, protective clothing, and use a sound piece of cardboard or wood when searching for hydraulic leaks. **DO NOT USE YOUR HANDS**
- If injured by injected fluid, see a doctor at once. If your doctor is not familiar with this type of injury, ask him to research immediately to determine proper treatment.

WARNING

DO NOT MODIFY MACHINE OR ATTACHMENTS

Modifications may weaken the integrity of the attachment and may impair the function, safety, life and performance of the attachment. When making repairs, use only the manufacturer's genuine parts, following authorized instructions. Other parts may be substandard in fit and quality. For loaders, never modify any ROPS (Roll Over Protection System) equipment or device.

!!!Any modifications must be authorized in writing by Werk-Brau or the manufacturer!!!

DANGER

NOTICE

SAFELY OPERATE THE EQUIPMENT

Do not operate equipment until you are completely trained by a qualified operator in how to use the controls, know its capabilities, dimensions, and all safety requirements.

See your operating machines manual for these instructions.

- Keep all step plates, grab bars, pedals, and controls free of dirt, grease, debris, and oil.
- Be sure that all bystanders are out of harms way when operating.
- Do not allow riders on the attachment or operating machine
- Do not operate the equipment from anywhere other than the correct operators position.
- Never leave equipment unattended with the engine running or with this attachment in a raised position.
- Do not alter or remove any safety feature from the operating machine or this attachment.
- Know your work site safety rules as well as traffic rules and flow. When in doubt on any safety issue, contact your supervisor or safety coordinator for an explanation.



SAFELY MAINTAIN AND REPAIR EQUIPMENT

- Do not wear loose clothing, or any accessories that can catch in moving parts. If you have long hair, cover or secure it so that it does not become entangled in the equipment.
- Work on a level surface in a well-lit area.
- Use properly grounded electrical outlets and tools.
- Use the correct tool for the job at hand. Make sure tools are in good condition.
- Wear all protective equipment specified by the tool manufacturer.

OPERATING PRECAUTIONS

⚠ WARNING

DO NOT IMPROPERLY USE COUPLER

This coupler is designed to couple attachments and not for any other use.

⚠ DANGER

BE AWARE OF SURROUNDING UTILITIES

Operator must be aware of all utility line and overhead electrical lines. Operations must be able to clear all lines safely.

NOTICE

⚠ DANGER

BE AWARE OF OVERHEAD DANGER

Operator must be aware of all possible overhead dangers that are within the range of motion of the operating machine.

⚠ WARNING

DO NOT OPERATE WITH A LOOSE ATTACHMENT

Visually check the coupler to verify attachments are secure and lock is fully engaged and that the center to center of the attachment matches the up with the coupler.

⚠ WARNING

PINCH POINTS

Personal injury could result from the careless misuse of this coupler. Keep hands and body parts clear of the coupler when it's in the process of hooking up to an attachment. Be sure the machine is off and the attachment is on the ground prior to making adjustments.

NOTICE

COUPLER EXTENDS TIP RADIUS

Notice adding a coupler to machine extends the tip radius. This can cause clearance issues on some machines making it possible for a coupled attachment to come into contact with the machine causing damage

Product Overview



Product Introduction

The Werk-Brau PT series is Werk-Brau's next generation of tilting innovation. More compact and powerful, the D-Tilt uses the same helical sliding spline technology that's been field proven for over 20 years.

Ideal for a broad range of tasks, the PT series will boost the versatility and productivity of your machine in countless ways when grading and excavating, ditch cleaning, metering fill material or landscaping.

To ensure its high quality performance and safe operation, the D-Tilt will need to be properly maintained. Please read the information in this manual carefully and follow all safety measures and maintenance schedules.

Operation Technology

D-Tilt uses an innovative, sliding-spline operating technology to convert linear piston motion into powerful shaft rotation. Each actuator is composed of a housing and two moving parts — the central shaft and piston.

Helical spline teeth on the shaft engage matching teeth on the piston's inside diameter. A second set of splines on the piston's outside diameter mesh with the gear in the housing.

Starting position

The piston is completely bottomed out. Bars indicate starting positions of piston and shaft. Arrows indicate directions they will rotate. The housing with integral ring gear remains stationary.

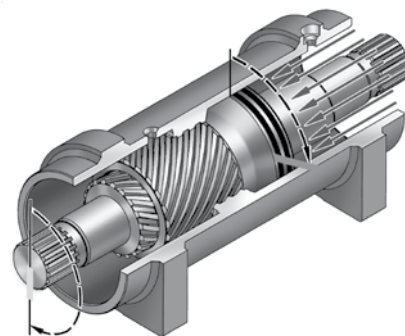
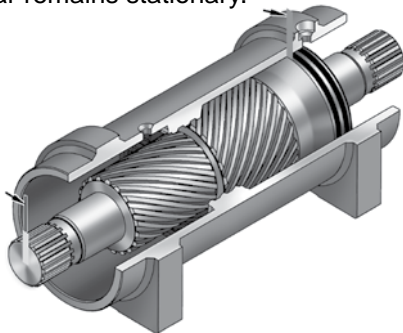

Ending position

When hydraulic pressure is applied to the piston, it moves axially, while the helical gearing causes the piston and shaft to rotate simultaneously. Applying pressure to the opposite port will return the piston and shaft to their original starting positions.

General Safety Guidelines

Cautionary Notices

Before beginning installation, operating of machine, or repair of the D-Tilt, there are several cautionary notices that should be considered. If you are not comfortable with repair or maintenance of this product, contact Werk-Brau or D-Tilt AG for assistance.

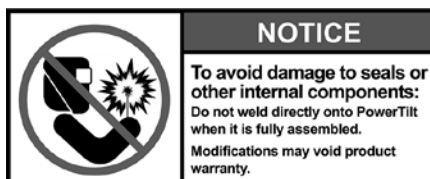
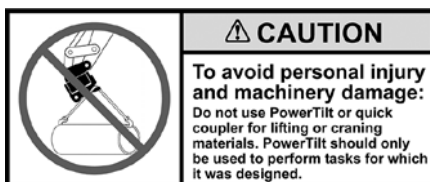
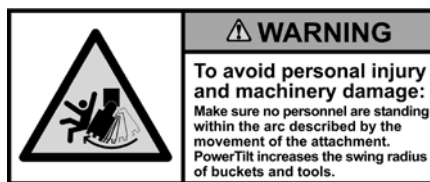
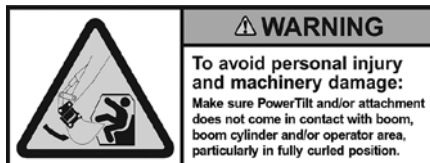

Other Safety Guidelines and Precautions

1. D-Tilt should only be used to perform tasks for which it was designed. Abusing the product and/or using it for purposes for which it was not intended can expose the operator and others to hazards as well as result in damage to the D-Tilt, carrier and/or other attachments.
2. Modification to the D-Tilt is done at the owner's risk and may void the warranty.
3. D-Tilt is designed for a maximum bucket width as noted below. Applying the full force of the excavator or backhoe to the corner of a wide bucket (e.g. corner digging with a wide bucket) may cause premature wear and/or reduced equipment life. It is also recommended that the bucket widths are not exceeded.

Maximum Recommended Bucket Width for Use with D-Tilt

d-tilt model	maximum Bucket Width
TD-030	1100 MM = 44"
TD-050	1200 MM = 48"
TD-070	1400 MM = 56"
TD-100	1700 MM = 68"
TD-180	1800 MM = 72"
TD-240	1900 MM = 76"
TD-300	2100 MM = 84"

4. A decrease in breakout force may be experienced due to the increased tip radius.
5. It is the owner's responsibility to be sure all safety equipment is in place and operating properly at all times. If safety decals fade, are damaged or become unreadable from a distance of 3 meters, they should be replaced immediately.

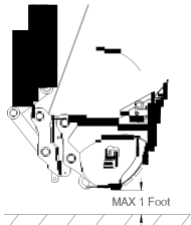
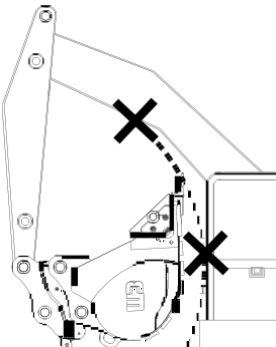

Be sure to post the provided warning decal to the cab of the carrier machine.

DANGER	
	<p>CRUSH HAZARD. Attachment may drop without warning if not properly attached. Consult owners manual for proper installation procedures. Failure to comply could result in death or serious injury.</p>
	<p>Attachment must be disengaged in the fully curled position. NEVER activate switch in any other attachment position.</p>
WARNING	
	<p>This machine is fitted with a quick coupler. This may lead to interference with the machine.</p>

- 6. D-Tilt should only be used in conjunction with attachments that do not adversely affect the stability of the machine.

Important Notice

Werk-Brau Corporation does not assume any responsibility beyond the design and performance of its construction equipment attachment products. The customer is solely responsible for engineering of mating structures, fasteners, and other associated components related to the installation of the product and its ultimate application.

	<p>WARNING</p> <p>For PTA, PTB or Custom Models: IMPROPER SELECTION, INSTALLATION OR USE OF HELAC OR POWERTILT AG PRODUCTS OR SYSTEMS MAY RESULT IN FAILURE AND CAUSE DEATH, PERSONAL INJURY OR PROPERTY DAMAGE. It is important to thoroughly analyze all aspects of your application and review current product information and guidelines.</p>	
---	--	---

Hydraulic Requirements and Plumbing

The installer of the D-Tilt is responsible for selecting the control circuits that are compatible with the excavator and meet the D-Tilt requirements. MOST LIKELY THE EXC AUXILIARY. If the D-Tilt is fitted with a hydraulic coupler bottom, use the coupler kit provided.

NOTICE When installing a new tool circuit or hydraulic lines, flush all the tool circuit lines with hydraulic oil prior to connecting the D-Tilt to flush contaminants.

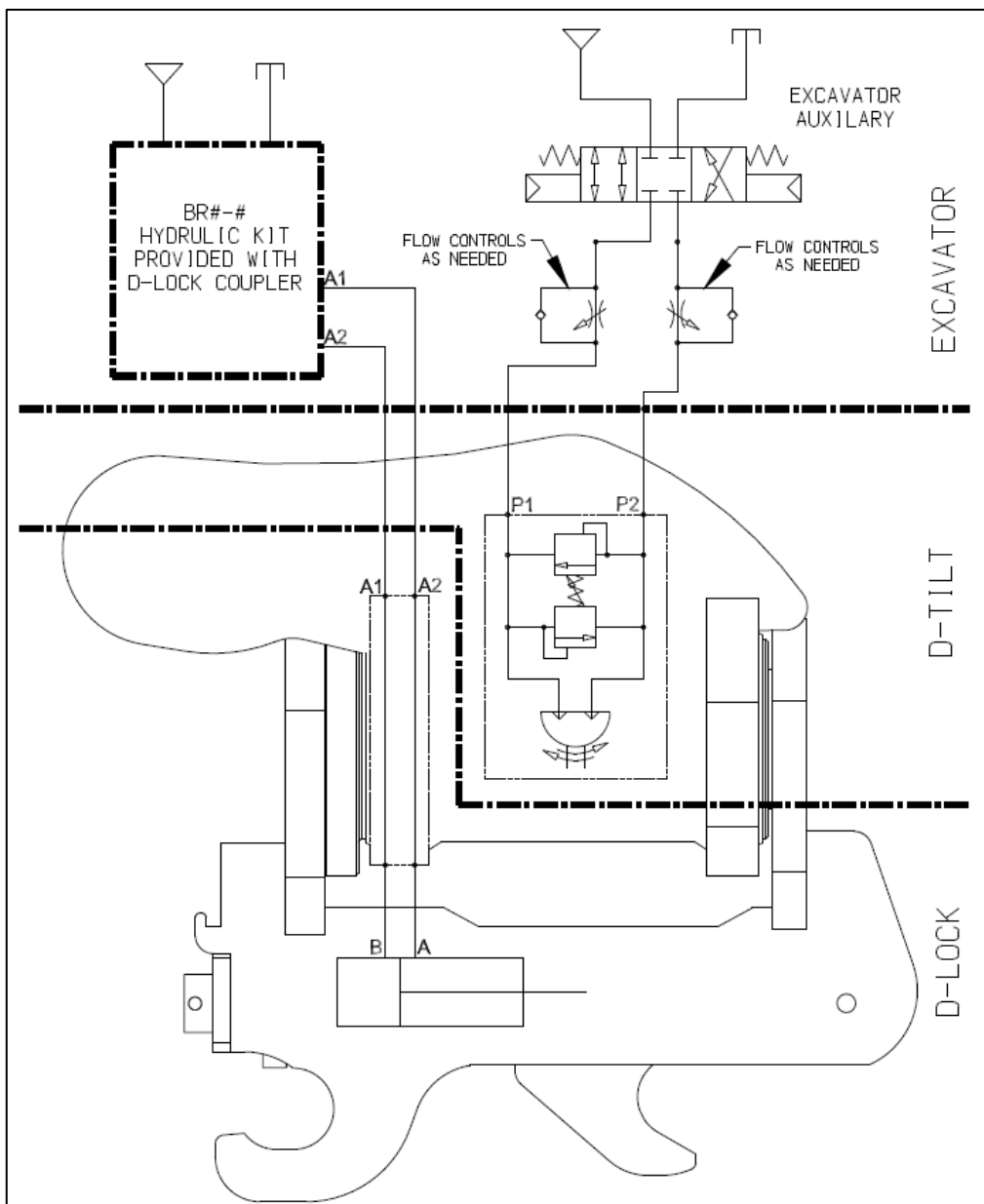

Hydraulic Requirements and Plumbing

Tool Circuit Requirements

Tool Circuit Requirements								
Model Sizes		030	050	070	100	180	240	300
Displacement	cm ³	623	936	1262	2065	2598	3474	4730
Suggested Oil Flow	l/min	6-19	9-28	13-38	19-58	26-78	35-105	47-142
Port Connections	BSPP	1/8	1/8	1/4	1/4	1/4	1/4	1/4
Hydraulic Pressures								
Cross Port Relief Valve Pressure**			220-230 bar					
Circuit Pressure			207 bar					
Maximum Circuit Back Pressure			40 bar					

* Suggested oil flows will yield a speed of 6 seconds at low end and 2 seconds at high end, stop to stop.

** D-Tils are equipped with factory-installed integral cross port relief valves.

Auxiliary Ports Orientation

Important Notice

When the auxiliary ports, A1 and A2, are used for activating a hydraulic coupler or any device where safety is an issue, the port orientation must be correct. If the auxiliary ports are reversed, a rotary union seal failure could activate release of the coupled device.

Pressure-clamp/pressure-release devices:

Aux 1 must always be used to provide hydraulic pressure to clamp or secure an attached device.

Aux 2 must always be used to provide hydraulic pressure to unclamp or release an attached device.

Spring-clamp/pressure-release devices:

Aux 2 must always be used to release spring-clamped, pressure-release devices.

Important Notice:

Failure of both rotary union seals could cause the release of a clamped device. Pressure at Aux 1 should render Aux 2 inoperable.

The Aux 1 circuit is inboard of the Aux 2 circuit. Therefore, failure of the inboard rotary union seal could cause the Aux 1 circuit to be pressurized by the main D-Tilt circuit, P1. In that case, the attached device would remain attached. Failure of both rotary union seals could cause both Aux 1 and Aux 2 to be simultaneously pressurized by P1. Attached devices should be configured to remain attached with Aux 1 and Aux 2 both pressurized at the same time.

Port Locations

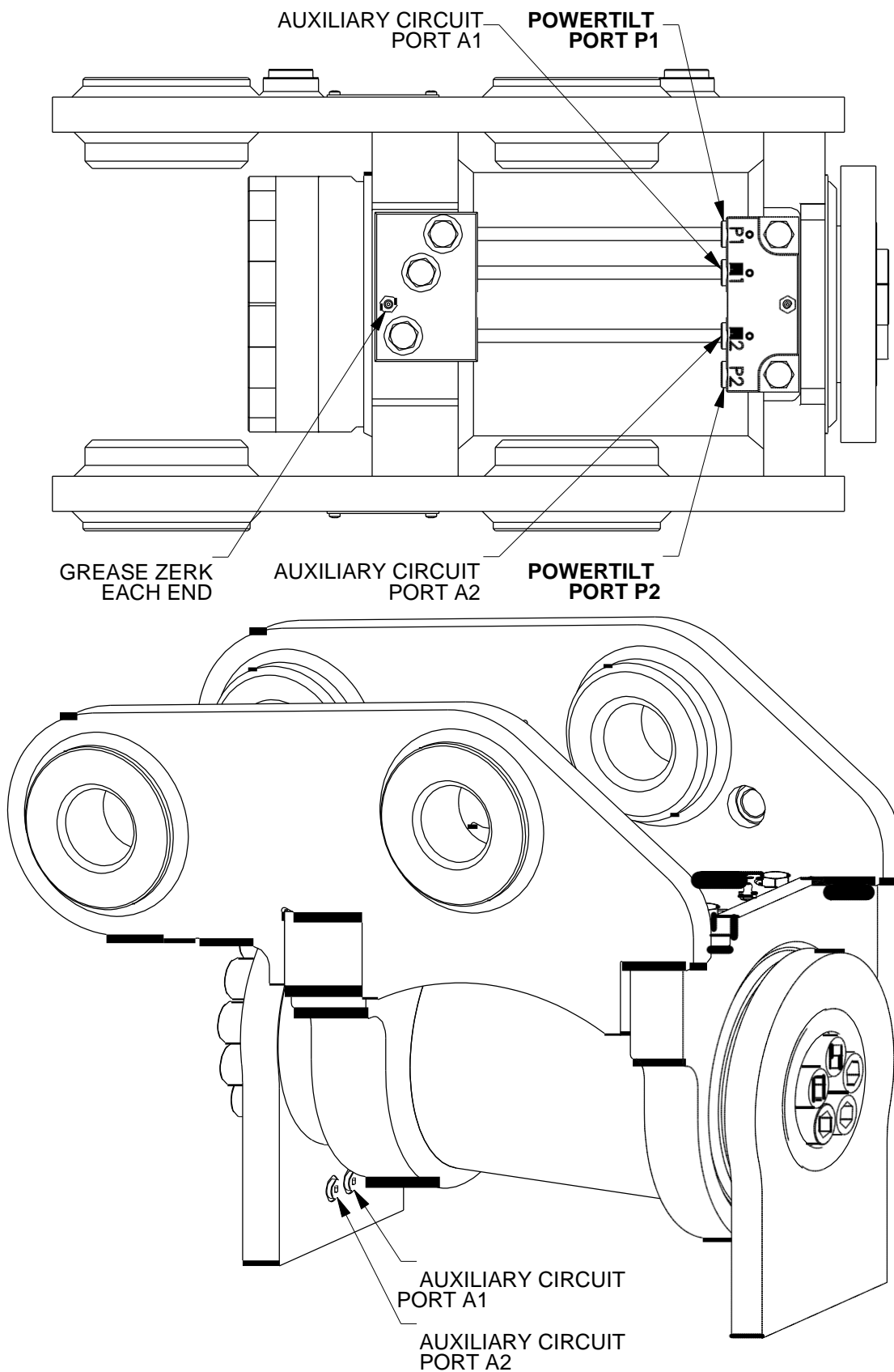

Coupler Welding and Rotary Union Lubrication

The auxiliary ports A1 and A2 on the D-Tilt housing connect to a rotary union in the torque output end of the D-Tilt. The rotary union is also a bearing and must have lubrication. The rotary union must be filled with oil prior to using the D-Tilt. Failure to do so will void the warranty and may cause catastrophic damage to the D-Tilt.

Welding Instructions

- If the torque foot has port plugs, remove the O-rings from the torque foot port plugs in ports A1 and A2 and re-install the plugs. Otherwise the O-rings will be damaged or destroyed during the welding process. The plugs will keep debris from entering the ports.
- The torque foot may now be welded.
- If the coupler ports will be connected to a two-line hydraulic coupler, it is not necessary to add oil to the rotary union. The bearings will be lubricated by the coupler hydraulic circuit oil. The air needs to be bled to prevent cavitation.
- If the coupler ports will be connected to a one-line hydraulic coupler or will be left unused follow the steps under "Filling the Rotary Union with Oil." This process will be required if a quick coupler is not included from the Werk-Brau or D-Tilt AG factory.

Torque Bolts

- The torque of the torque foot and hub bolts must be checked before placing the D-Tilt in service. Bolt sizes and torque values are on pages 34-35.

Filling the Rotary Union with Oil

- If there is only one line to the coupler, that line should be connected to A2 and air bled. A1 should then be filled with oil.
- If no line is connected to A2, continue with this procedure.
- Remove actuator port plugs A1 and A2 and torque foot port plugs A1 and A2.
- If the torque foot has no auxiliary ports, it is for a mechanical coupler. In that case, remove the 1/16" NPT plug located in the shaft face.
- If a coupler is not connected, it is desirable to have the A1 and A2 circuits 80%-90% full of oil with some air to allow for expansion during use.
- Replace the port plugs.

Flushing and Air Purging Procedure

Purpose and Interval

Since the D-Tilt uses a low fluid volume, working fluid normally does not return to the hydraulic supply tank. The flushing procedure should be performed at approximately 100 hours of operation and at approximately 1000 hour intervals thereafter to remove accumulated wear products and to refresh the working fluid. The air purging procedure should be performed if there is any indication that air has entered the actuator.

NOTICE Remove the bucket or working tool from the coupler prior to servicing the rotary actuator

NOTICE Shut down the excavator prior to loosening or removing hydraulic lines.

NOTICE This procedure requires the removal of hoses which will contain hydraulic fluid. A means should be provided for containing spilling hydraulic fluid. See the chart below to determine the approximate amount of fluid which will be ejected per flushing rotation.

Flushing Procedure

NOTICE It is important to follow the steps of this procedure exactly to minimize the entry of air into the hydraulic system.

1. Note the location of D-Tilt ports P1 and P2 and the corresponding connections to the excavator auxiliary hydraulic system hoses or pipes on the stick boom.
2. Curl the D-Tilt (extend the stick cylinder) and position the stick boom and main boom until the D-Tilt is in the approximate position shown in Figure 1 below (fully inverted, D-Tilt ports facing down) and at a convenient distance from the ground.
3. Cycle the D-Tilt fully in both directions about 10 times. This will tend to move accumulated particles near the port locations.
4. Viewed from the cab of the excavator, rotate the D-Tilt fully clockwise against the stop and leave it there.
5. Carefully note the switch position for clockwise rotation.

Auxiliary Line Flushing

6. Locate the hose which joins D-Tilt port P1 to the excavator hydraulic system. Prepare for leakage, and slightly loosen the connection at the excavator hose or pipe system junction, Figure 1, to relieve residual pressure. Then carefully disconnect the hose.
7. Place the free end of that hose into the container for contaminated hydraulic fluid.
8. Locate the hose which joins D-Tilt port P2 to the excavator hydraulic system. Prepare for leakage, and slightly loosen the connection at the D-Tilt P2 junction to relieve residual pressure. Then disconnect the hose.
9. Connect the free end of the hose to the open excavator port junction creating a jumper between the two excavator ports.
10. Cycle the D-Tilt hydraulic system with the jumper hose for at least 10 seconds in one direction to completely flush the auxiliary system.
11. This completes the auxiliary line flushing.

Flushing and Air Purging Procedure

D-Tilt Flushing Continued

D-Tilt Flushing

12. Prepare for leakage, and slightly loosen the jumper hose connection at the excavator hose or pipe system P1 junction to relieve residual pressure. Then carefully disconnect the hose.
13. For safety, install a plug in the open excavator pipe or hose P1 port.
14. Connect the free end of the hose from the excavator P2 port to the D-Tilt P2 port.
15. The free end of the P1 hose should be in the container.
16. Note the correct switch position for CCW rotation and moderately rotate the D-Tilt fully counterclockwise against the stop and leave it there. The fluid in the D-Tilt will be ejected into the collection container.
17. The P1 port hose will still contain contaminated hydraulic fluid.
18. Swap the P1 and P2 port hoses at the actuator.
19. Now using the CCW rotation switch position rotate the D-Tilt fully CW against the stop and leave it there. This will clear the original P1 port hose.
20. Again, swap the P1 and P2 port hoses back to their original positions.
21. Though not normally required, this process may be repeated several times to assure that the D-Tilt is fully flushed with clean hydraulic fluid.
22. Reconnect the free end of the P2 port hose to the excavator hydraulic system P2 port connection.
23. Ensure that all hoses are routed correctly and all hose retainers are replaced.
24. Cycle the D-Tilt several times and check for leaks.
25. This completes the flushing process.

Approximate Fluid Capacities for Full Stroke

TD035	1 liter
TD055	1.3 liters
TD080	2 liters
TD140/180	2.6 liters
TD240	3.5 liters
TD350	4.7 liters

Purging Air from the D-Tilt

1. Curl the D-Tilt out until the D-Tilt ports are facing upward.
2. Prepare for hydraulic oil leakage.
3. Slightly loosen ("crack") the D-Tilt P1 port fitting.
4. Rotate the D-Tilt clockwise by pressurizing the P2 port. This will allow trapped air to escape at the P1 port fitting.
5. Tighten the P1 port fitting and slightly loosen ("crack") the D-Tilt P2 port fitting.
6. Rotate the D-Tilt fully counterclockwise by pressurizing the P1 port. This will allow trapped air to escape at the P2 port fitting.
7. Repeat the procedure as necessary.
8. This completes the air purging procedure.

Flushing and Air Purging Procedure

Purging Air from the Coupler Ports

Follow this procedure if a hydraulic coupler is installed.

1. Position D-Tilt so that ports A1 and A2 are facing up.
2. Retract the coupler cylinder by pressurizing port A2.
3. Prepare for leakage.
4. Slightly loosen (crack) the A2 port fitting.
5. Extend coupler cylinder by pressurizing port A1. This will allow air to escape at the A2 port fitting.
6. Tighten the A2 port fitting and loosen (crack) the A1 port fitting.
7. Retract coupler cylinder by pressurizing port A2. This will allow air to escape at the A1 port fitting.
8. Tighten the A1 port fitting.
9. Repeat procedure as necessary.

Flushing and Air Purging Procedure

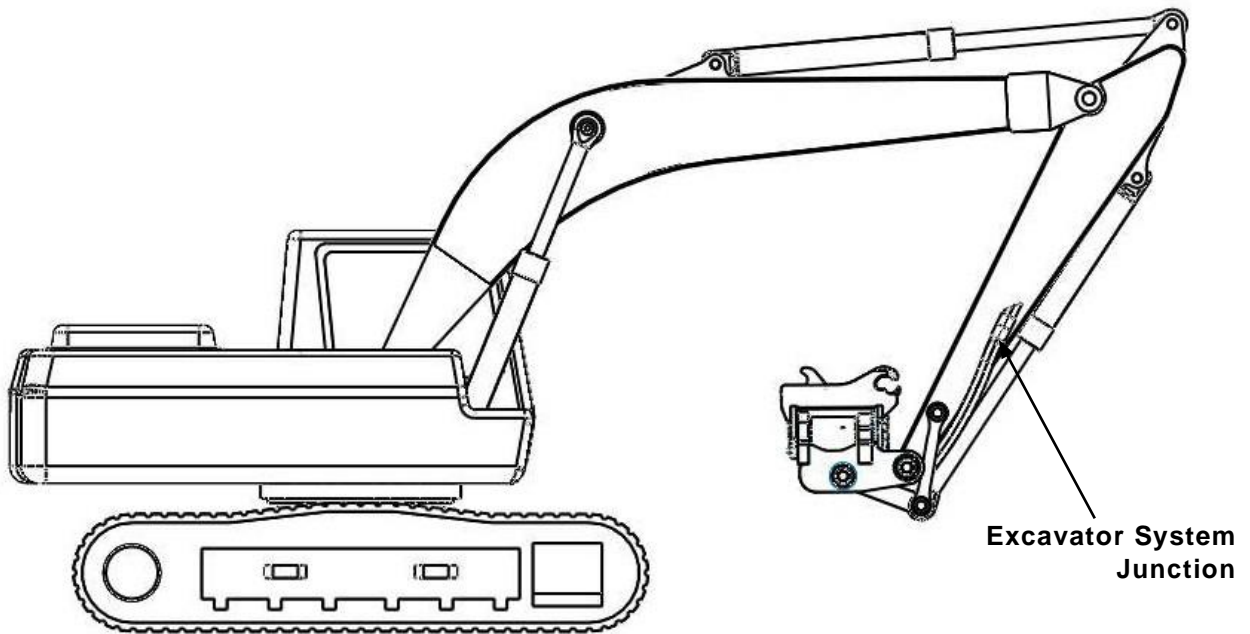

Figure 1: Boom Positions for Flushing Procedure – D-Tilt Inverted

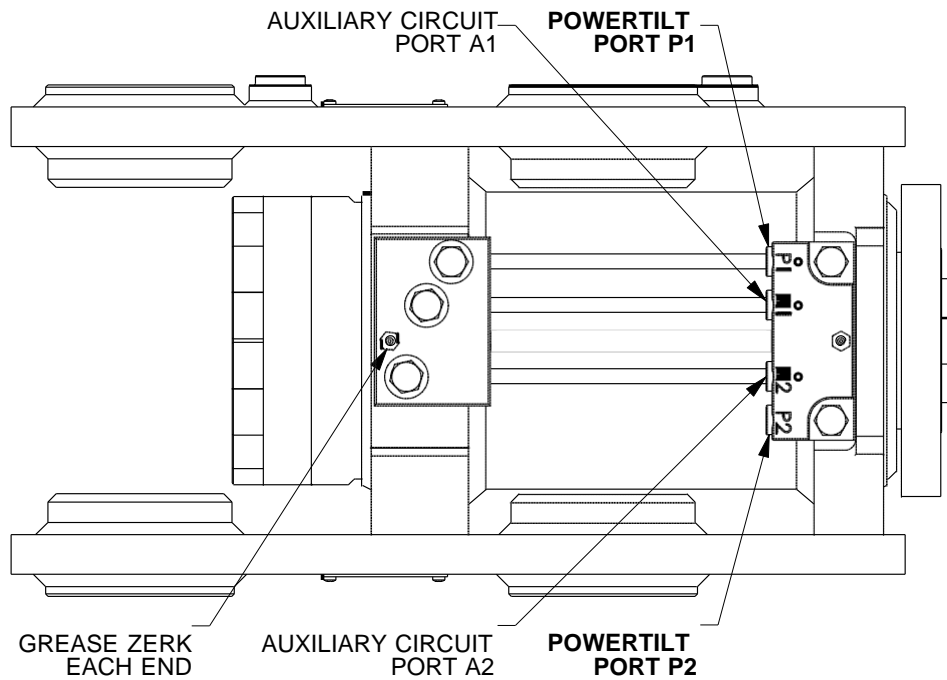

Figure 2: D-Tilt Port Locations

Flushing and Air Purging Procedure

D-Tilt Rotary Union Circuit Flushing

If the D-Tilt unit has a hydraulic coupler operated through the integral rotary union, follow the flushing directions of the coupler manufacturer. Otherwise the rotary union, which acts partly as a bearing, should be flushed with fresh hydraulic oil. If the D-Tilt has an access hole at the bottom of the drive bolt circle, use the Flushing Procedure for Manual Torque Feet. If there is no access hole, use the Flushing Procedure for Hydraulic Torque Feet.

Flushing Procedure without Hydraulic Torque Feet:

1. Remove quick coupler.
2. Provide a means for injecting low pressure hydraulic oil into the A1 and A2 ports.
3. The D-Tilt unit does not require inverting for this procedure.
4. Prepare for a small amount of fluid leakage from the shaft face ports.
5. Remove the A1 and A2 port plugs from the manifold.
6. Remove the 1/16 NPT plugs from the shaft face.
7. Inject oil into the A1 and A2 ports until fresh oil appears at the shaft face ports.
8. Replace the 1/16 NPT pipe plug.
9. Reinstall coupler.
10. This completes the flushing procedure.

Flushing Procedure for Hydraulic Torque Feet:

1. Provide a means for injecting low pressure hydraulic oil into the A1 and A2 port.
2. The D-Tilt unit does not require inverting for this procedure.
3. Prepare for a small amount of fluid leakage from the torque foot ports.
4. Remove the A1 and A2 port plugs from the manifold and from the torque foot.
5. Inject oil into the A1 and A2 ports until fresh oil appears at the torque foot outlet ports.
6. Replace the port plugs and tighten according to the chart below.
7. This completes the flushing procedure.

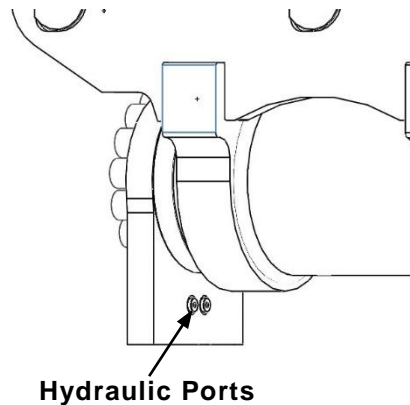

Maintenance

Daily

1. Grease the two grease fittings with a high quality Lithium-based grease. Apply grease until clean grease passes the exclusion seal from around the shaft and end cap. Wipe off excess grease when done. Severe operating conditions such as abrasive dust or prolonged submersion in water may require more frequent grease applications.
2. Make sure that grease passes the exclusion seal when grease is applied to the grease fitting.
3. Inspect the D-Tilt for loose, worn or damaged components and replace or repair immediately.
4. Mounting pins should be greased upon installation and thereafter according to the equipment manufacturer's instructions.

Every 1,000 Hours

Follow flushing procedure. See pages 11-14.

Troubleshooting Guide

Problem	Possible Cause	Solution
D-Tilt does not hold position	<p>Cross port relief is opening due to excess down pressure from excavator</p> <p>Faulty cross port relief valve.</p> <p>Control valve leaking oil.</p> <p>Seals leaking oil.</p>	<p>This is normal. The integral cross port relief valve is designed to protect the D-Tilt from excessive internal pressures that can damage the unit.</p> <p>Remove the integral cross port relief valve and visually inspect for damage or debris. Check pressure setting of the cross port relief valve which can be found in the Tool Circuit Requirements Chart shown on Page 8.</p> <p>Test, repair or replace as needed.</p> <p>Test and replace seals as needed.</p>
D-Tilt swings in only one direction.	<p>Single directional control valve is being used.</p> <p>Cross port relief valve damaged.</p>	<p>Replace with bi-directional control valve.</p> <p>Inspect, test and replace as needed.</p>
D-Tilt has spongy feel side to side.	<p>Air in D-Tilt or hydraulic circuit.</p> <p>Diameter of tubing/hoses larger or longer than recommended.</p>	<p>Bleed air from circuit and check for cause.</p> <p>Install new tubing/hoses with recommended diameters which can be found in the Tool Circuit Requirements Chart shown on Page 8.</p> <p>Install pilot operated check valve in lines as close as possible to D-Tilt.</p>
Side to side bucket movement.	<p>Some movement is normal due to clearance required between internal spline teeth.</p>	<p>Normal movement is 1° to 1-1/2°. Consult factory.</p>
D-Tilt squeals at maximum tilt or when stalled.	<p>Relief valve is opening from machine pressure.</p>	<p>Check relief pressure, and if within range, reduce the pressure from the machine to below relief pressure setting.</p>

TD-055 Assembly Drawing

*TD-055 Shown

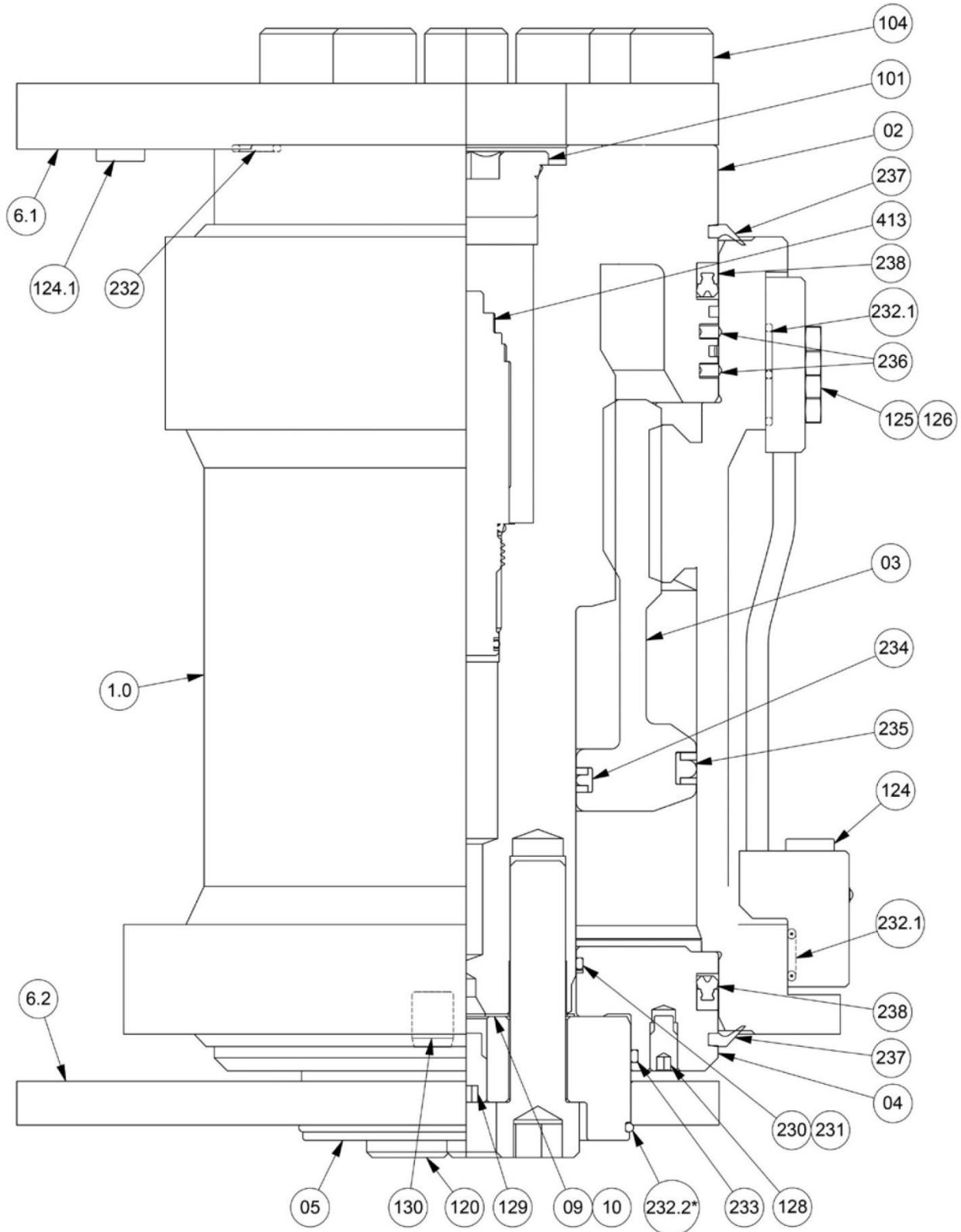

* O-RING USED FOR SHIPPING LOOSE IDLER FOOT ONLY, REMOVE AFTER COUPLER IS WELDED.

TD-055 Exploded View

*TD-055 Shown. See parts list for quantities of an item.

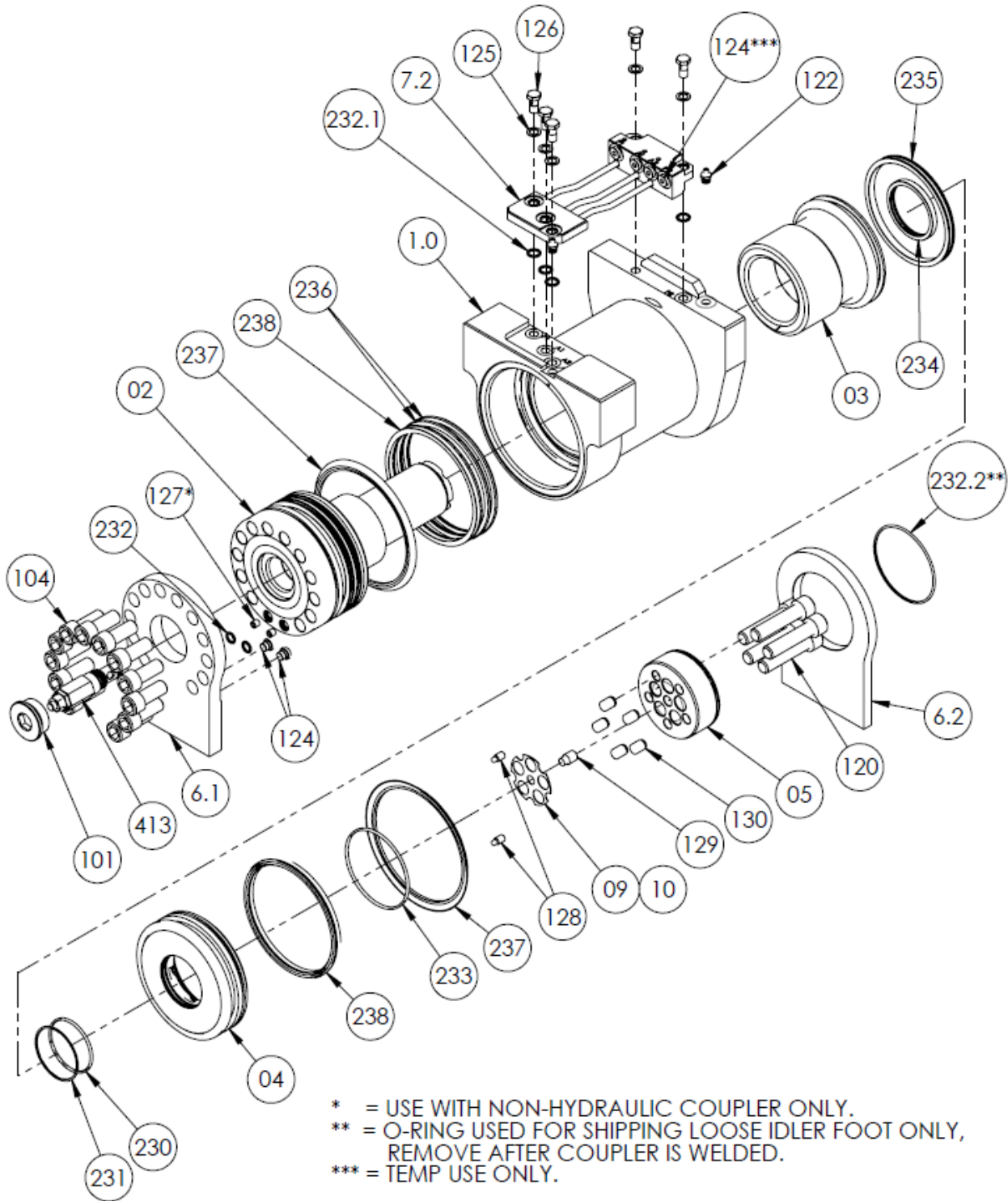

TD-080 Assembly Drawing

With cross-port relief from hub end

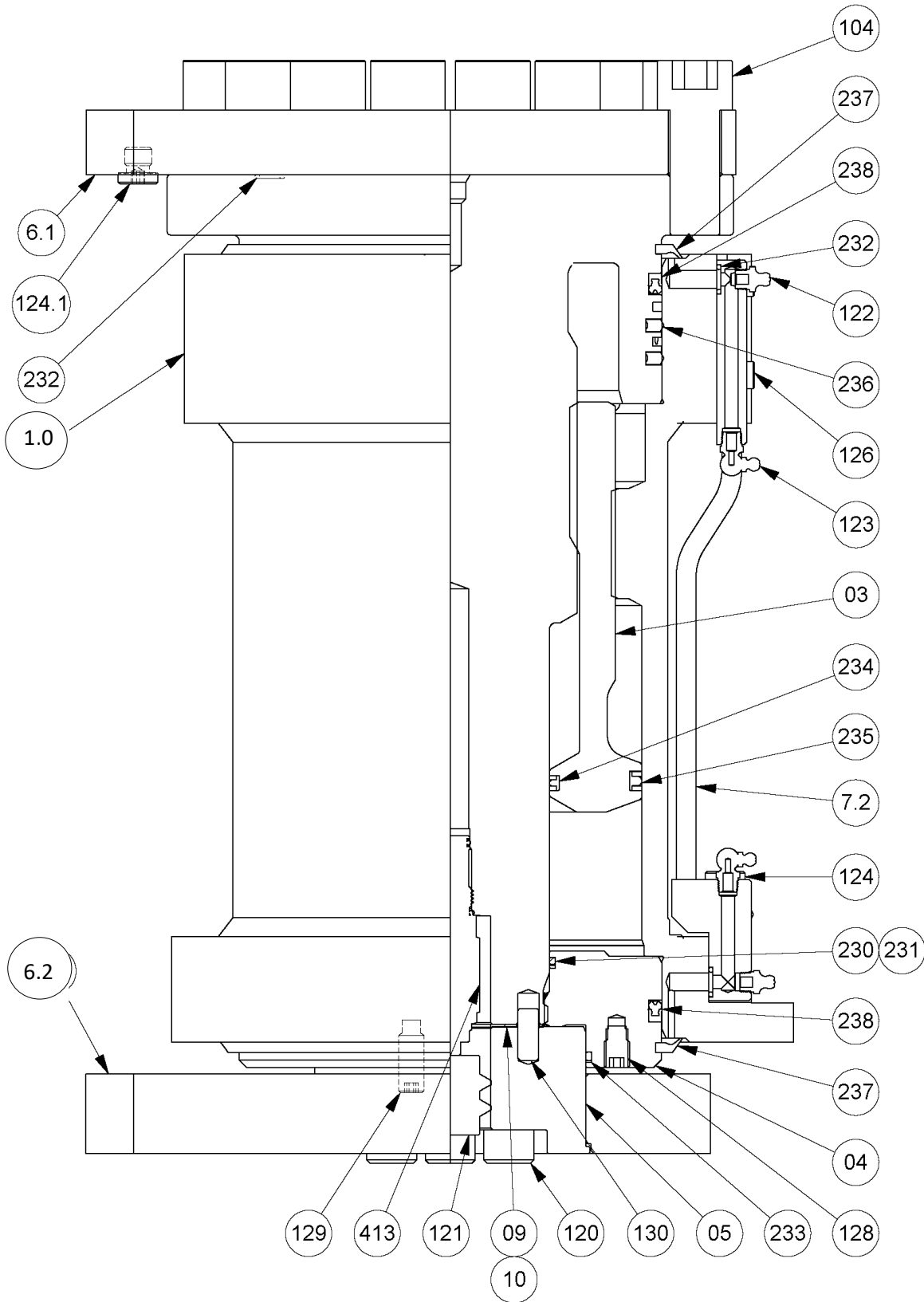

TD-070/080/140/180/240/350 Assembly Drawing

With cross-port relief from shaft flange end

*TD-180 Shown. See parts list for quantities of an item.

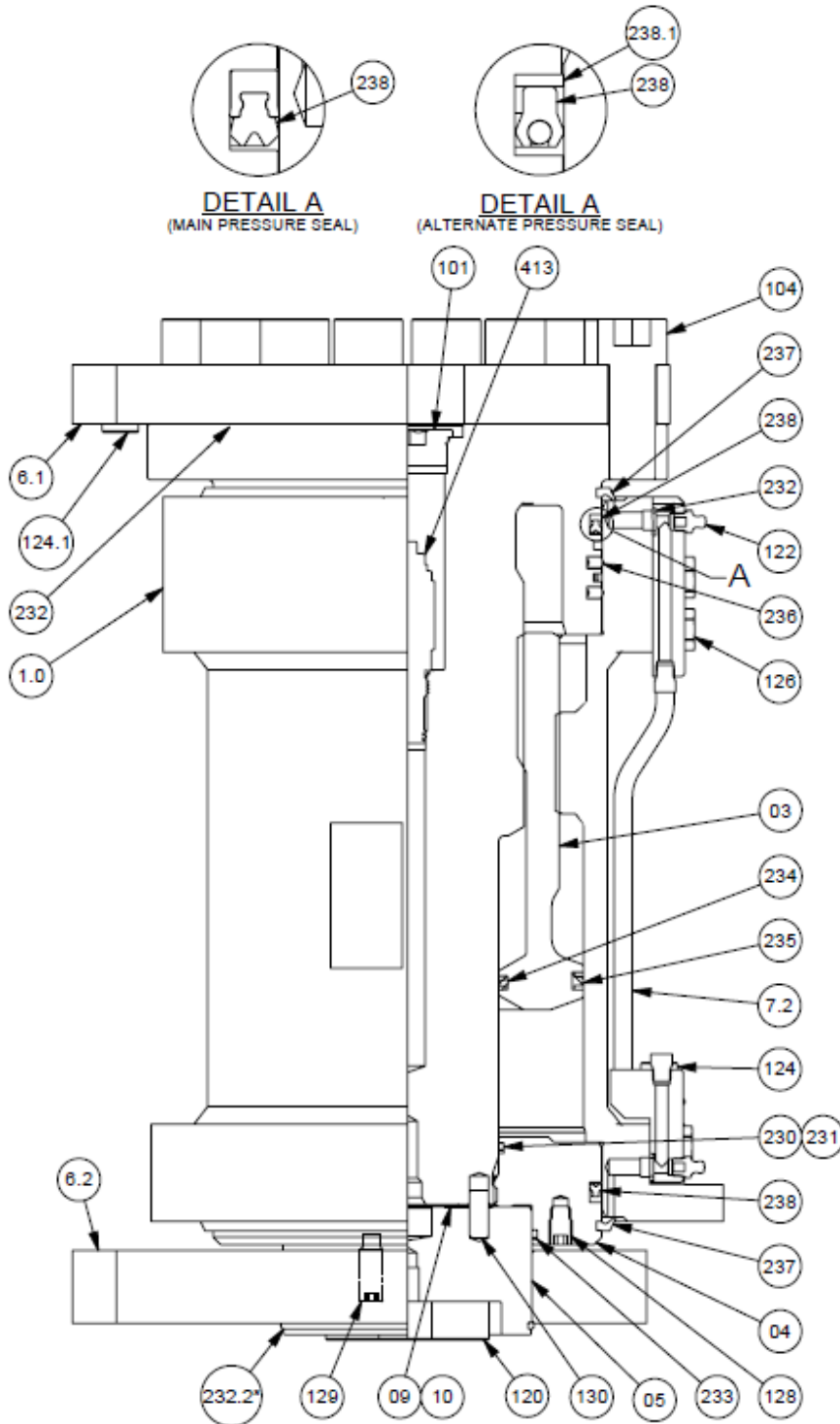

* O-RING USED FOR SHIPPING LOOSE IDLER FOOT ONLY, REMOVE AFTER COUPLER IS WELDED.

TD-070/080/140/180/240/350 Exploded View

*TD-180 Shown. See parts list for quantities of an item.

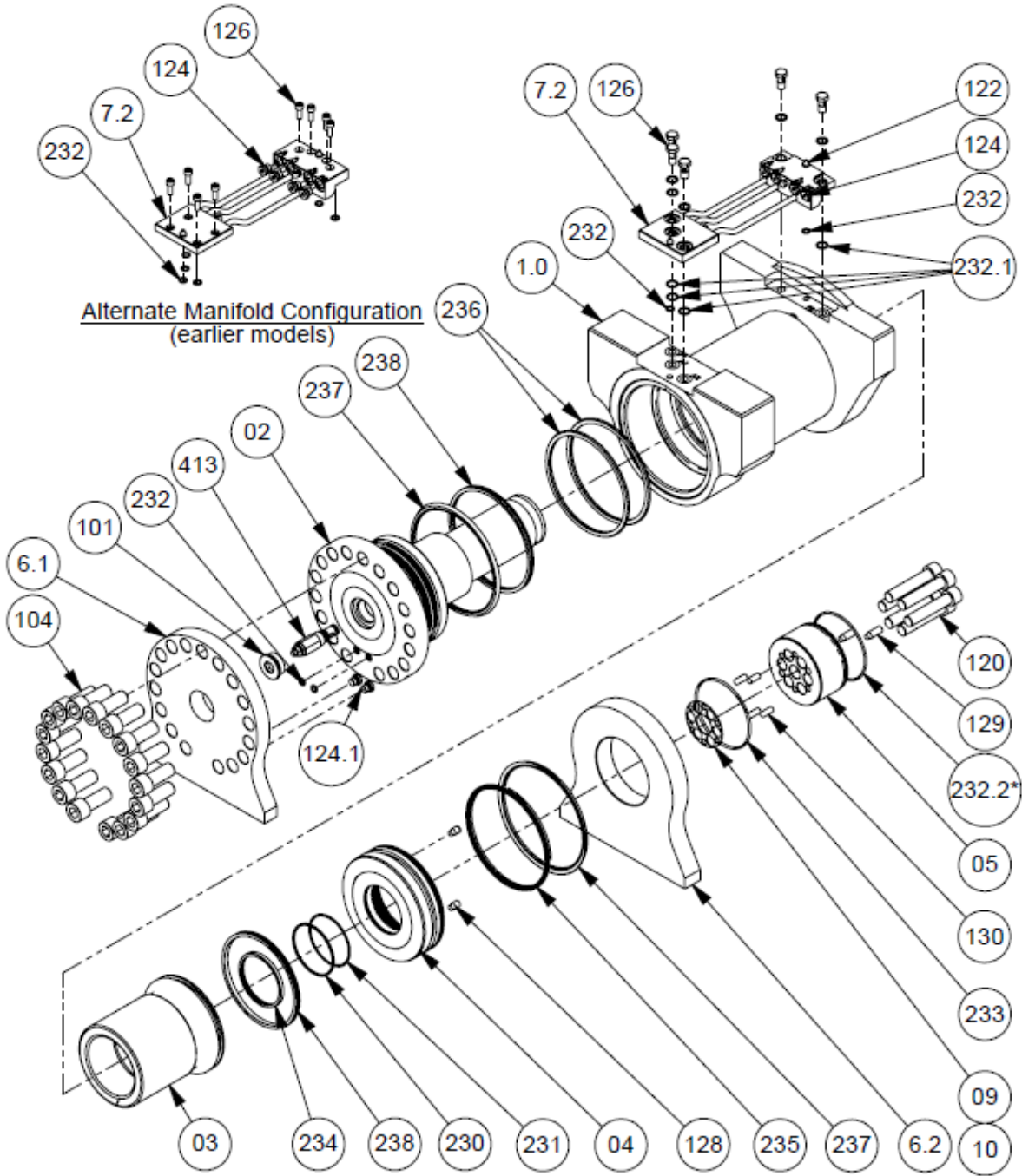

* O-RING USED FOR SHIPPING LOOSE IDLER FOOT ONLY, REMOVE AFTER COUPLER IS WELDED.

Parts List

PARTS

Item	Description	Quantity
01	Housing	1
02	Shaft	1
03	Piston	1
04	End Cap	1
05	Hub	1
6.1	Torque Foot	1
6.2	Idler Foot	1
09/10	Shim Pack	1
7.2	Manifold Assembly	1
413	Relief Valve	1

HARDWARE

Item	Description	Quantity
101	Plug	1
104	Screw	See table page 35
120	Screw	6
120	Screw, TD-030	4
120	Screw, TD-050, 070	5
122	Grease Fitting	2
124	Plug (BSPP 1/4)	4
124.1	Plug (BSPP 1/4)	2
125	Crush Washer	5
126	Screw	8
126	Banjo bolt	5
128	Screw, Set	See table page 35
129	Screw, Set	See table page 35
130	Hub Pin	See table page 35

SEALS

Sold as "kit" only

Item	Description	Quantity
230	Seal; O-Ring	1
231	Seal; O-Ring Backup	1
232	Seal; O-Ring	See table page 35
232.1	Seal; O-Ring	See table page 35
233	Seal; O-Ring	1
234	Seal; T-Seal	1
235	Seal; T-Seal	1
236	Seal; Rotary Union	2
237	Seal; Exclusion	2
238	Seal	2

Product Inspection

Make sure the D-Tilt is thoroughly cleaned prior to disassembly. Continue to clean all machined parts in a wash tank and dry with compressed air. Inspect the D-Tilt for corrosion prior to disassembly.

Severe corrosion can make it difficult to remove the hub, set screws or the end cap. If corrosion is evident, soak the screws with penetrating oil for several hours before disassembly.

Removal of Coupler

1. Clamp D-Tilt to a secure table.

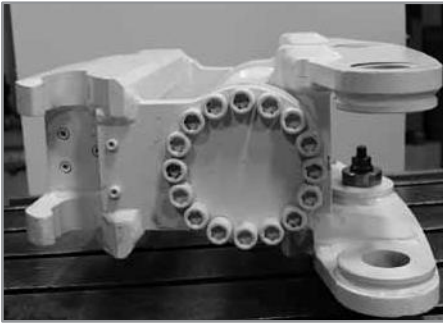

2. Remove bolts from hub. Use a jacking screw(s) to remove the hub.

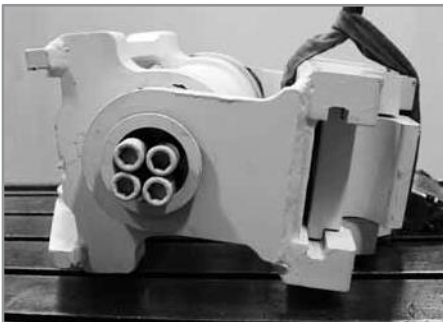

3. Remove the flange bolts and remove the coupler from the D-Tilt.

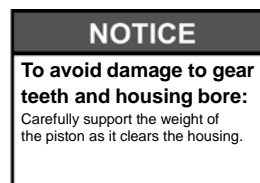
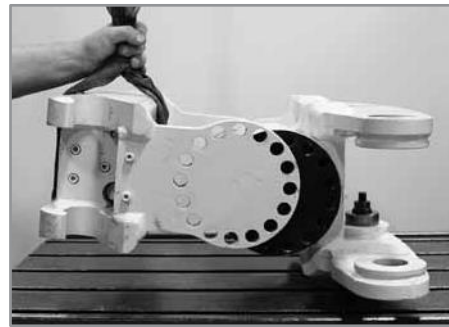

Disassembly of D-Tilt

1. Remove manifold from D-Tilt.



2. Remove o-ring seals from manifold

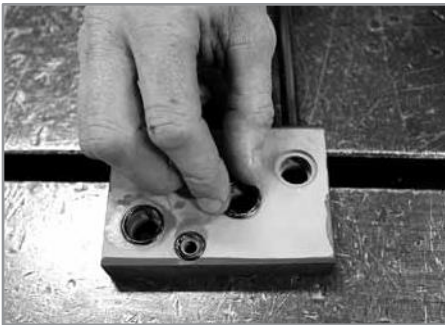

3. Remove hub screws from end cap if not already done.



4. Remove hub from end cap if not already done.



5. Remove end cap from housing.

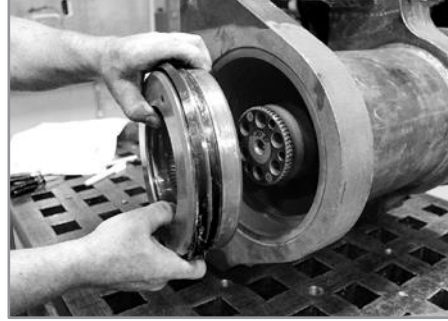

6. Insert two flange bolts and using a bar, rotate the shaft counter clockwise until it clears the seals.

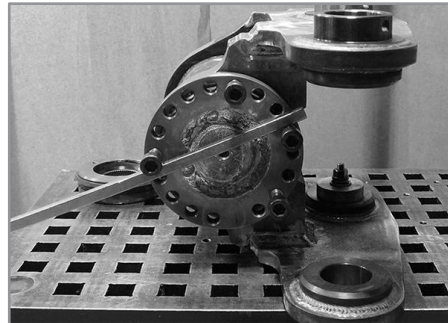

7. Carefully remove the shaft.

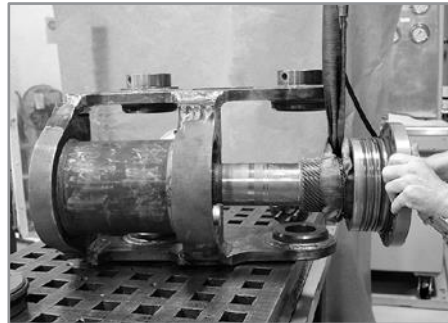

8. Use a hammer or other soft face tool to remove piston sleeve.

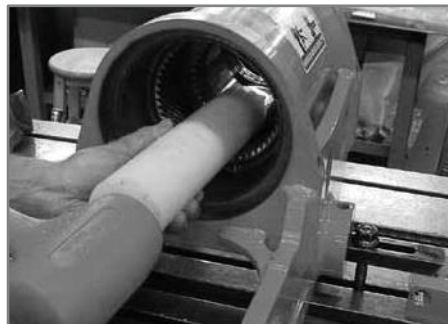

Disassembly of D-Tilt

9. Remove piston sleeve from housing.



13. Remove backup ring seal from piston sleeve.

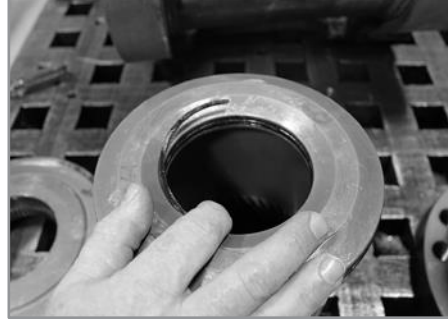

10. Remove piston seal from piston sleeve.



14. Remove o-ring seal from end cap.

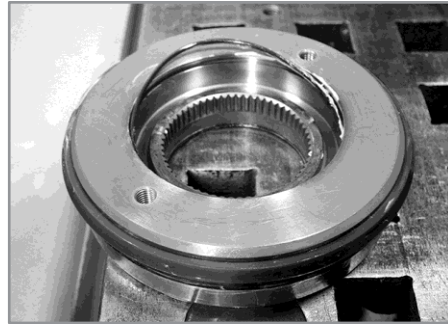

11. Remove backup ring seal from piston sleeve.



15. Remove backup ring seal from end cap.



12. Remove rod seal from piston sleeve.



16. Remove exclusion seal from end cap.



Disassembly of D-Tilt

17. Remove pressure seal from end cap.



21. Remove exclusion seal from shaft.



exclusion seal

18. Remove first rotary seal from shaft.

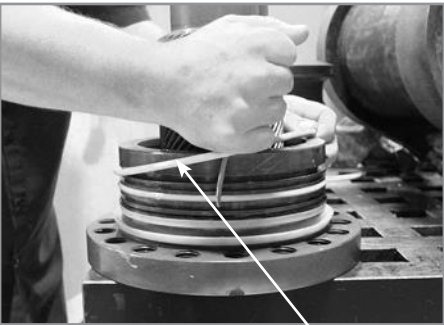

rotary seal

19. Remove second rotary seal from shaft.

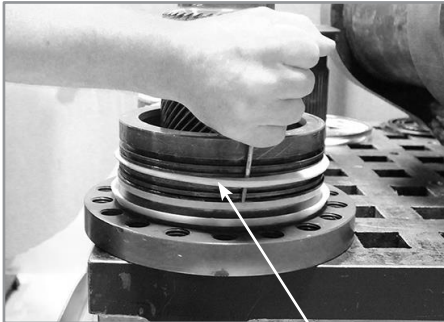

rotary seal

20. Remove pressure seal from shaft.

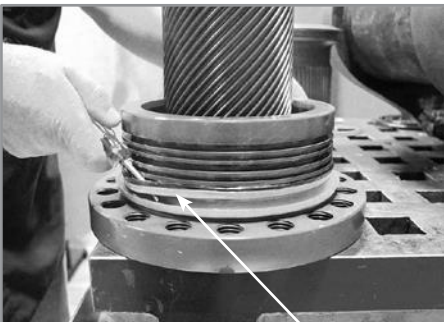

pressure seal

Shims Replacement

NOTICE

This procedure is required only if the housing, end cap or shaft have been replaced.

1. Assemble the shaft and end cap only into the housing without any seals. It is difficult to get an accurate measurement with the seals installed. To get an accurate measurement with the piston and seals installed, use a bar clamp or other device to pull the shaft and end cap tightly against the housing thrust bearings.
2. Use a depth micrometer or feeler gauge to carefully determine the step between the shaft end and the end cap counterbore.



3. Record the measurement. The replacement shims consist of .020" shims and .004" shims. In final assembly, use sufficient shims to produce a stack equal to the recorded measurement plus .001" to .004". This will determine the running clearance between the thrust bearings. Too much clearance will result in a loose actuator. Too little may result in bearing damage or an inoperable D-Tilt.

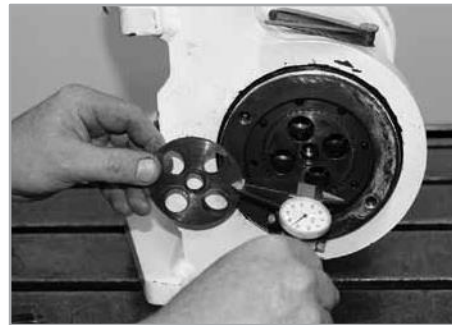

4. Disassemble the D-Tilt and proceed to assembly.
5. After assembly, verify that the shimming is correct by checking the end play during testing. See page 36.

Dry Assembly

	CAUTION
	Spraying fluids: Contents under pressure. Wear approved eye protection. Use caution when removing port plugs and fittings.

	CAUTION
	To avoid injury or damage to product: Secure product to work bench.

NOTICE
To avoid contamination to machined parts: Make sure work area is clean.

For personnel not familiar with the assembly of the D-Tilt it is recommended to assemble the unit without seals to verify timing and rotation limits.

Caution: Support all components carefully to avoid damage to any edges or sealing surfaces.

Align existing timing marks on Piston with those on the Ring Gear in the housing. Push Piston in until it bottoms out on the Ring Gear. Align existing timing marks on Shaft to those on the mating gear of Piston. Rotate Shaft into gearing until it bottoms out on housing thrust face. Install End cap, hub and screws. Snug screws down and check for complete rotation of shaft. Depending on unit, rotation will be 180-186 degrees or 120-126 degrees. If timed correctly the two small O-ring counterbores should rotate either 90° or 60° each way from the 6:00 position. Once correct timing and assembly steps are verified disassemble unit and complete assembly per steps listed.

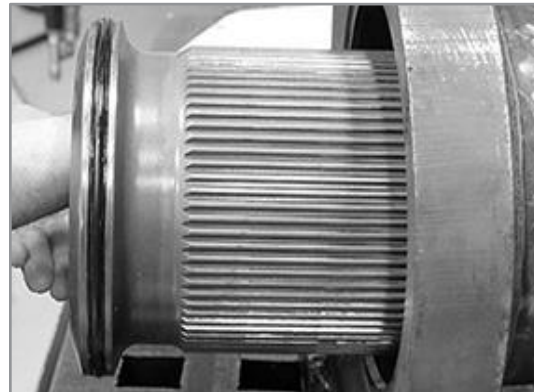

Assembly of D-Tilt

NOTICE

Wash and clean parts thoroughly.

1. Oil and install exclusion seal onto shaft.



2. Oil and install pressure seal onto shaft.

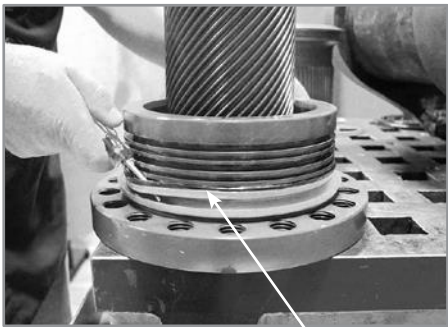

pressure seal

3. Oil and install second rotary seal onto shaft.

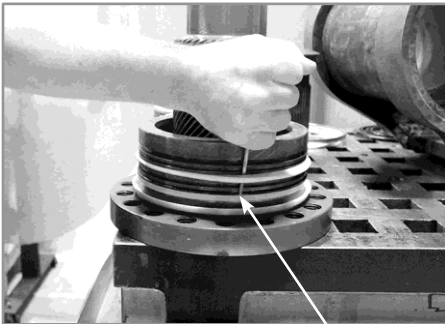

rotary seal

4. Oil and install first rotary seal onto shaft.

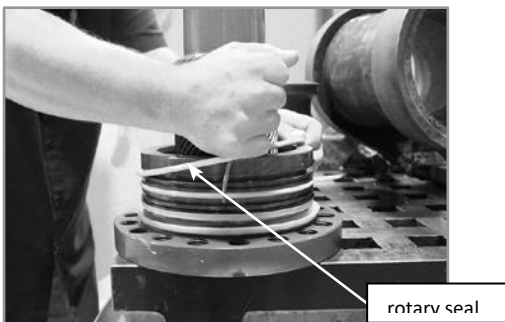

rotary seal

5. Oil and install pressure seal onto end cap.



6. Oil and install exclusion seal onto end cap.



7. Oil and install backup ring seal onto end cap.



8. Oil and install o-ring seal onto end cap.

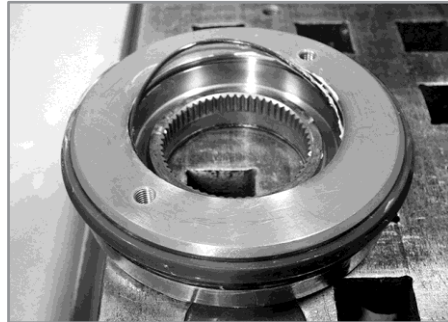

Assembly of D-Tilt

9. Oil and install backup ring seal onto piston sleeve.

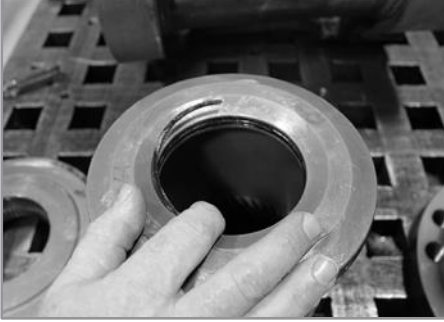

10. Oil and install rod seal onto piston sleeve.



11. Oil and install backup ring seal onto piston sleeve.



12. Oil and install piston seal onto piston sleeve.



13. Oil housing and piston sleeve.

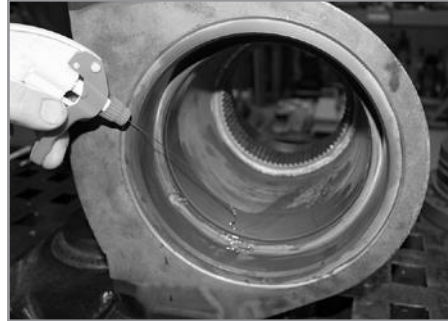

14. Install piston sleeve into housing.

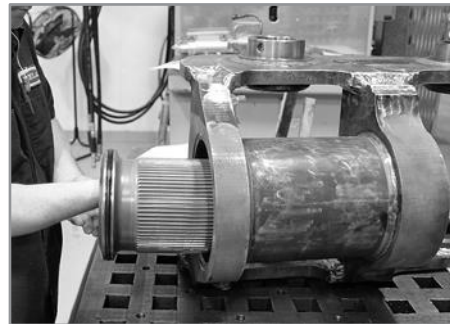

15. Align timing marks with the piston sleeve and housing.

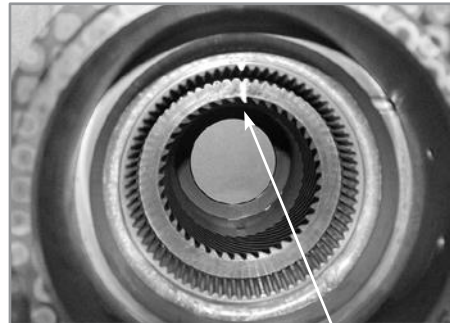

timing marks

16. Use a soft hammer to install piston sleeve.



Assembly of D-Tilt

17. Pack exclusive seal with grease. Oil and install the shaft into piston sleeve.

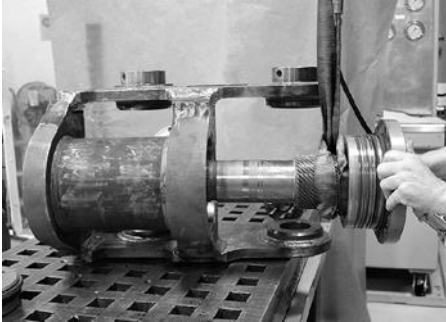

18. Align timing marks with piston sleeve and shaft.



timing marks

19. Use a bar to turn the shaft clockwise into the piston sleeve.

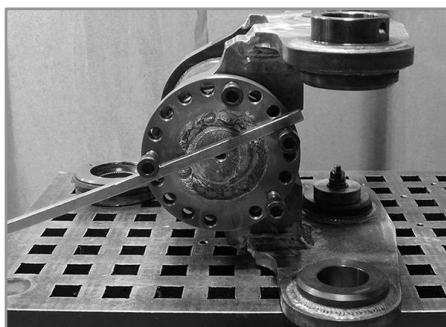

20. Pack exclusive seal with grease. Oil and install end cap into housing. Use soft hammer to push the end cap into the housing.

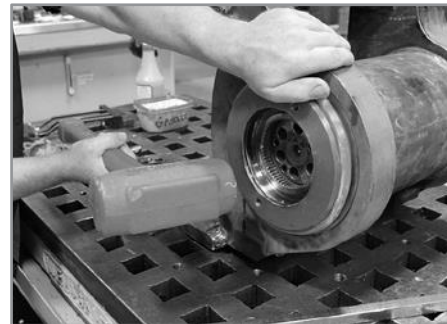
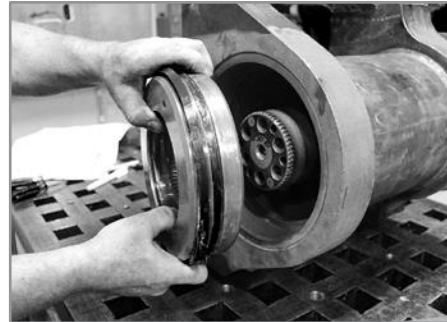

21. After tightening and removing bolts, measure the distance from the end cap surface to the shaft face and record measurement for later use. Now separate shims to approximately .022-.007" thicker than the gap value recorded in previous step and install under hub to ensure proper end play.

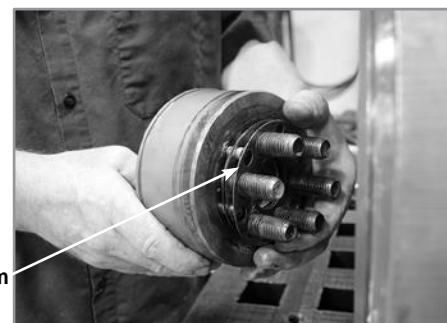

shim

Assembly of D-Tilt

Coat bolt threads with Loctite Nickel Anti-Seize #77164 or equivalent and install bolts.

22. Ensure that the coupler port o-rings are in place.

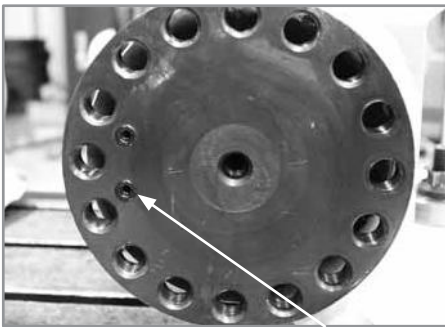
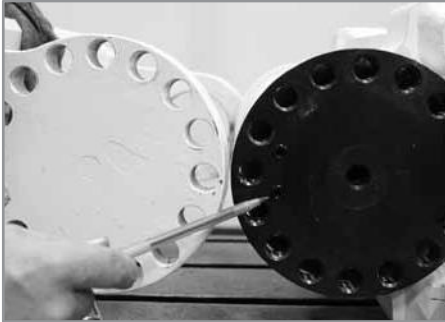

Port O-rings

23. Install the coupler and secure it with two loose flange bolts.

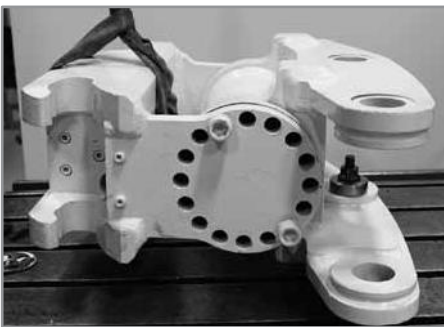

24. Install the hub with the shims.



25. Coat bolt threads with Loctite Nickel Anti-Seize #77164 or equivalent. Insert hub bolts and tighten per table on page 30.



NOTICE

If the shaft, housing or end cap have been replaced the correct quantity of shims will have to be determined. See the instructions under Shims Replacement on page 28.

26. Coat bolt threads with Loctite Nickel Anti-Seize #77164 or equivalent. Insert bolts and tighten per table on page 30. At this time D-Tilt can be tested and inspected for leaks.

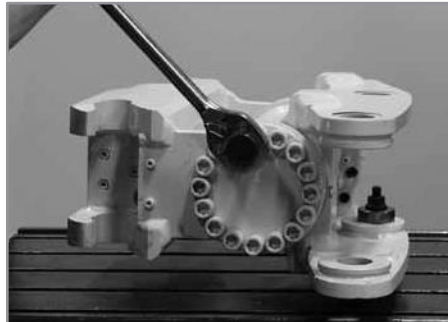

Assembly of D-Tilt

27. Install o-ring seals into manifold if using manifold.

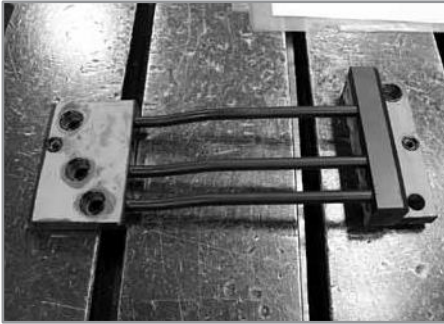

28. Install manifold onto D-Tilt. Torque to value in table on page 36.



D-Tilt Timing

Check timing by assuring that the D-Tilt can be rotated 90°/60° depending on unit rotation, each way from the 6:00 position. This check can be performed during dry assembly by rotating the D-Tilt with a suitable bar inserted between bolts inserted into the drive face. The check can be performed by operating the D-Tilt hydraulically after assembly.

If the timing is not correct, the unit must be disassembled and timed correctly.

Installation or replacement of relief valve cartridge

Oil seals and threads. Torque to 136 Nm.



Fastener Torque Specifications

Torque Values for Port Plugs

Plug Size	Torque Value - Hollow Hex Head Plugs Nm
BSPP G1/8	14 +/- 1
BSPP G1/4	31 +/- 1
BSPP G3/8	65 +/- 4

Torque Values for Banjo Bolts

Size	Torque Nm
BSPP G1/8	20 +/- 1
BSPP G1/4	50 +/- 3

Torque Values for Metric Fasteners

COARSE THREAD

Fastener Size	Socket Head Bolt (grd 12.9) Nm
M10 x 1.50	70 +/- 3
M12 x 1.75	125 +/- 5
M16 x 2.00	310 +/- 7
M20 x 2.50	615 +/- 20
M24 x 3.00	1100 +/- 27
M30 x 3.50	2150 +/- 41

FINE THREAD

Fastener Size	Socket Head Bolt (grd 12.9) Nm
M10 x 1.50	70 +/- 3
M16 x 1.50	340 +/- 7
M20 x 1.50	660 +/- 20
M24 x 2.00	1140 +/- 27
M30 x 2.00	2270 +/- 41

* All fasteners must be grade 12.9

D-Tilt Specifications

	TD-030	TD-035	TD-055	TD-080	TD-140/180	TD-240	TD-350
Output Torque							
Nm @ 207 bar	1 630	2 600	4 375	6 650	13 300	17 875	24 900
in-lbs @ 3000 PSI	14 400	22 900	38 700	58 800	117 600	158 200	220 400
Holding Torque							
Nm @ 225 bar	6 425	9 350	14 850	20 450	40 725	53 100	70 330
in-lbs @ 3250 PSI	56 900	82 800	131 400	180 900	360 400	470 000	622 400
Design Straddle Moment Load							
Nm @ 225 bar	9 490	17 650	30 400	51 100	137 200	197 800	267 650
in-lbs @ 3250 PSI	84 000	156 100	269 000	452 200	1 214 360	1 750 500	2 368 700
Torque Foot Bolt Size & Quantity							
Item 104	M12 x 1.75 16 each	M16 x 2.0 12 each	M20 x 2.50 12 each	M20 x 2.50 14 each	M24 x 3.00 17 each	M30 x 3.50 16 each	M30 x 3.50 18 each
Hub Bolt Size & Quantity							
Item 120	M16 x 1.5 4 each	M16 x 1.5 5 each	M20 x 1.5 5 each	M20 x 1.5 5 each	M20 x 1.5 6 each	M24 x 2.0 6 each	M30 x 2.0 5 each
Item 128 Quantity	2	2	2	2	2	2	2
Item 129 Quantity	1	1	1	1	2	2	2
Item 130 Quantity	4	5	5	5	4	4	5
Item 232 Quantity	2	2	4	8 or 4 with banjo manifold	8 or 4 with banjo manifold	4	4
Item 232.1 Quantity	4	4	4	4 with banjo manifold	4 with banjo manifold	4	4

Testing and Greasing

	⚠ WARNING
	Pinch point hazard: Moving parts can cause serious injury. Keep hands clear during operation.

	CAUTION
	Spraying fluids: Contents under pressure. Wear approved eye protection. Use caution when removing port plugs and fittings.

	⚠ CAUTION
	To avoid injury or damage to product: Secure product to work bench.

NOTICE
To avoid contamination to machined parts: Make sure work area is clean.

Testing the Carrier's Hydraulic System

If symptoms of poor performance develop, refer to the Troubleshooting Guide on Page 15 for general instructions. If you need help with more specific application issues, contact Werk-Brau or D-Tilt AG.

It is the responsibility of your service technician to verify that the carrier and hydraulic circuit are operating correctly. Because the D-Tilt receives its power from the carrier, a thorough check of the carrier hydraulic system is mandatory before performing any D-Tilt service or adjustments.

Filling Rotary Union with Oil.

See page10 for instructions.

Testing and Greasing

Attach the D-Tilt to either a hydraulic test bench, excavator or portable pump for greasing and testing. Make sure the D-Tilt is secured to prevent unwanted movement. Install the grease fittings.

1. After the D-Tilt is assembled but before it is put back into service, the exclusion seals and grease cavity must be packed with Lithium grease.
2. Locate the grease fittings or ports on the top of the D-Tilt and using a grease gun, pack the exclusion seal areas with grease until it exhausts from around the shaft and end cap. Clean excess grease as required.

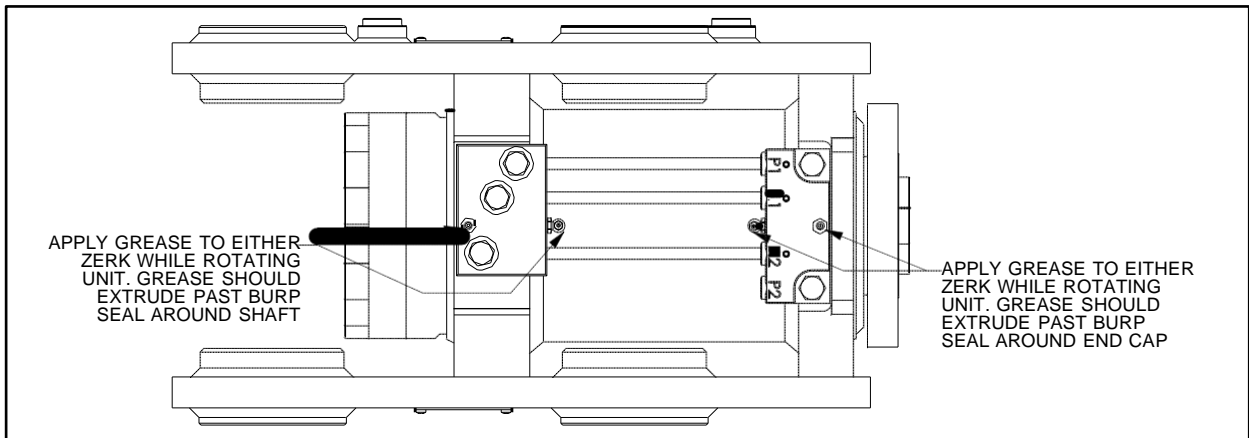

Testing and Greasing

3. Cycle the D-Tilt slowly and re-grease as necessary. During testing, it is recommended the D-Tilt be cycled 20 to 30 times to check for leaks and the proper degrees of rotation.
4. Measure end play with a dial indicator. Rotate D-Tilt all the way one direction and zero out the dial indicator while the D-Tilt is still pressurized. Rotate the D-Tilt all the way the other direction. Take the reading from the dial indicator while still pressurized. The measurement should be between .002" (.05 mm) and .008" (.20 mm). If the measurement is not within specification, shims will need to be added or removed to bring the measurement within specification.

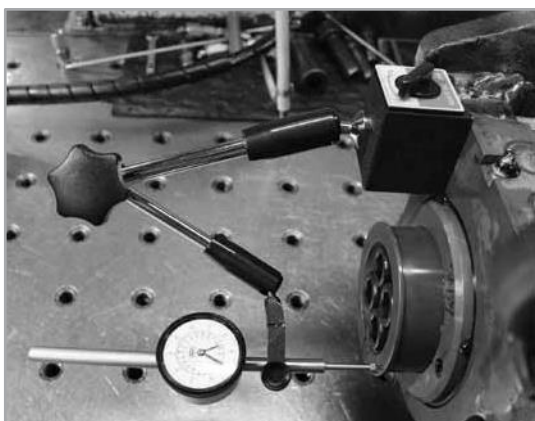

Testing for Leakage

1. Connect a 210 bar test gauge into the hydraulic line to Port P1. Slowly pressurize until the shaft reaches the end of rotation and bottoms out externally, e.g. the shaft bracket or torque foot contacts the housing or mounting bracket.

NOTICE

If the shaft is not completely bottomed out, hydraulic fluid will exhaust from Port P2 at a high velocity during step 2.

2. Remove the hydraulic line to Port P2. Pressurize Port P1 to 175 bar. Check for leakage at Port P2 and from around the main shaft and end cap seals. Leaks indicate improperly installed or damage parts.

3. Reconnect the hydraulic line to Port P2 and pressurize as in Step 1 above.
4. Check for leaks at Port P1 and around the main shaft and end cap seals as in Step 2 above.
5. Plug port A1 at the shaft ports or torque foot ports.
6. Remove the A2 and P1 hydraulic hose.
7. Apply pressure to A1 port.
8. There should be no flow from A2 or P1.
9. Remove the A1 hydraulic hose.
10. Apply pressure to A2.
11. There should be no flow from A1 or externally past main shaft seal.

Testing the Cross Port Relief Valve

The integral cross port relief valve vents hydraulic oil around the internal piston assembly of the D-Tilt at approximately 225 bar.

To test the valve:

1. Connect a 250 bar test gauge into the line to Port P1. Pressurize until the shaft reaches the end of rotation and bottoms out externally, e.g. the shaft bracket or torque foot contacts the housing or mounting bracket.
2. Relieve pressure to P2 and disconnect the hydraulic hose and cap off the hose end.
3. Install a temporary hydraulic hose to P2 with the end of the hose vented to an appropriate container.

NOTICE

The cross port relief valve is set at the factory and cannot be adjusted.

4. Slowly pressurize Port P1 noting the pressure at which oil flows from P2. The relief should vent at approximately 225 bar.
5. Test at Port P2 using the same procedure.
6. If test pressure does not meet specification, the valve must be replaced. If piston seal leakage is suspected, relief port test plugs are available from the factory.

Warranty

See Werk-Brau.com for warranty information

Notes

TOUGH JOBS DEMAND TOUGH ATTACHMENTS



WERK-BRAU CO. INC.,
2800 Fostoria Rd
P.O. Box 545
Findlay, Ohio 45839

1-800-537-9561 *phone*
419-422-7207 *fax*
Werk-Brau.com