

REV	DATE	CHANGE DESCRIPTION	BY	CHECKED
A	-	RELEASED TO PRODUCTION	JAS	-
-	-	-	-	-
-	-	-	-	-

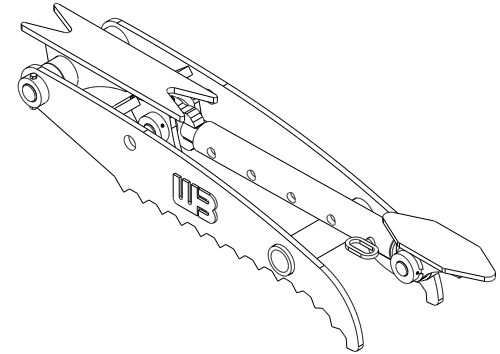

EZG3-TC3-XXR

#	DESCRIPTION	PART #	AMT
1	WELDED ASSEMBLY	EZG3-TC3-XX	1
2	PIVOT MOUNT	EZG3-TC3-MT	1
3	PIVOT BUSHING	BU-5073	2
4	GREASE ZERK	60102	1
5	PIVOT PIN	EZG3-TC3-PP	1
6	3/8-16 UNC X 3 1/2 BOLT	13117	1
7	3/8 LOCK WASHER	33622	1
8	3/8-16 UNC NUT	36306	1
9	CYLINDER PIN	EZG100-CP-1	1
10	ROLL PIN	64289	2
11	MOUNT PIN	EZG100-CP-425	1
12	RIGID ARM	EZG-RG-4991	1
13	INSTRUCTIONS	INST-EZG-TC2	1
14	DANGER STICKER	D-DANGER EZG	2
15	CYLINDER MOUNT	EZG100-MOUNT	1

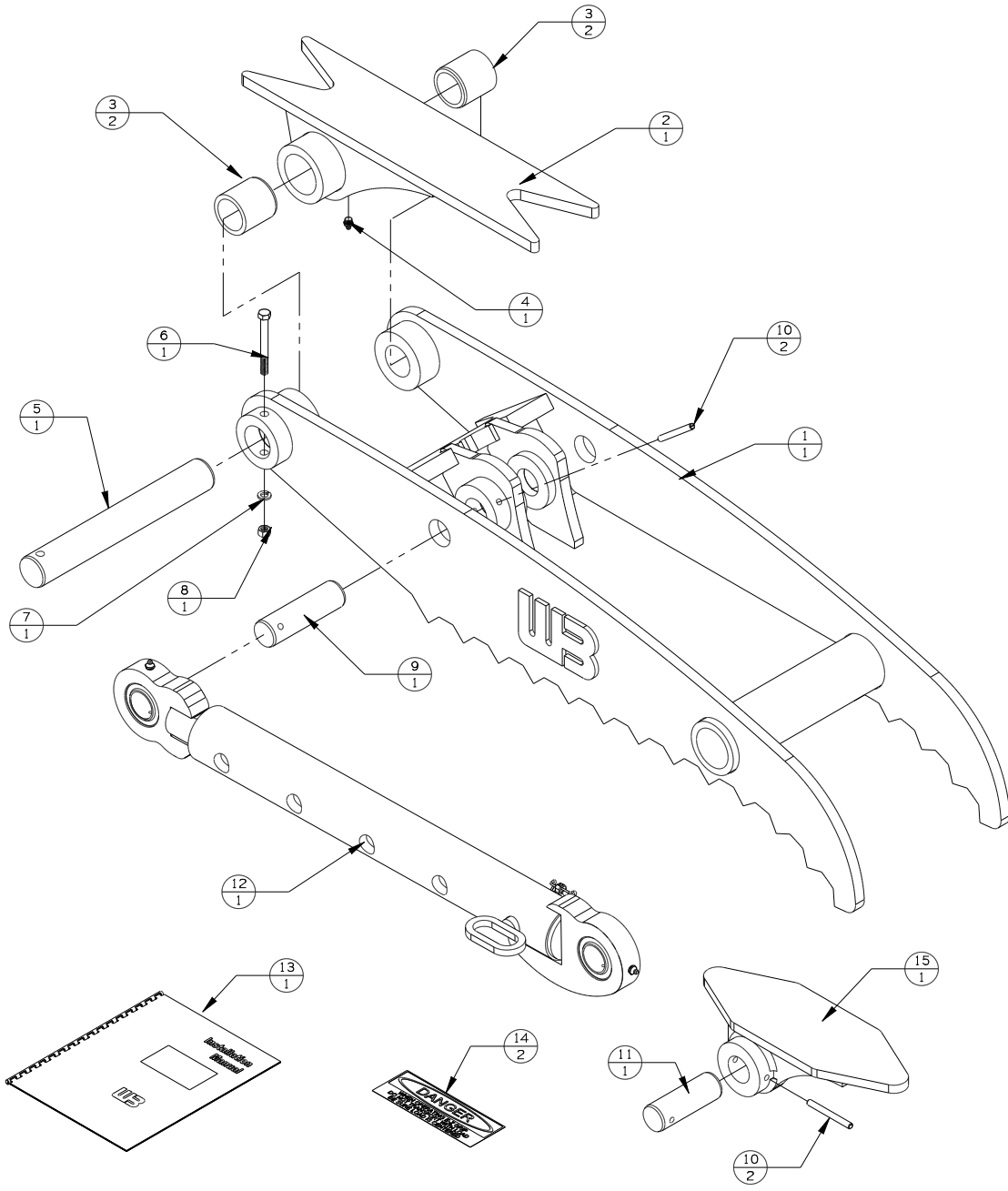

WERK-BRAU CO., INC.
 2800 FOSTORIA AVE. P.O. BOX 545 FINDLAY, OHIO 45840-0545
 www.werkbrau.com PHONE: 419-422-2912 FAX: 419-422-7207

INCH 1/X: ± 1/16 X: ± 1.50
 .X: ± .1 X.X: ± 0.80
 .XX: ± .01 X.XX: ± 0.25
 .XXX: ± .005 ANGLE ± 0.5°
 .XXXX: ± .0005 NOT TO SCALE

WELD SPEC: WELDS TO CONFORM TO P7.PRO6-WB ARC WELDING QUALITY STANDARD

DATE: 7-28-16

WEIGHT: - Lbs.

MACHINE: -

PART No.: EZG1-TC3-XX

FILE NAME: EZG3-TC3-42.CKD

THIS PRINT AND THE INFORMATION CONTAINED HERE ON IS A CONFIDENTIAL DISCLOSURE, THE SUBJECT MATTER OF WHICH IS THE PROPERTY OF: WERK-BRAU CO., INC.

DRAWN:

A
REVISION

