

REV	DATE	CHANGE DESCRIPTION	BY	CHECKED
A	2-6-18	RELEASED TO PRODUCTION	JAS	-
B	2-28-18	CHNAGE PIVOT MOUNT TO OLDER DESIGN	JAS	-
-	-	-	-	-

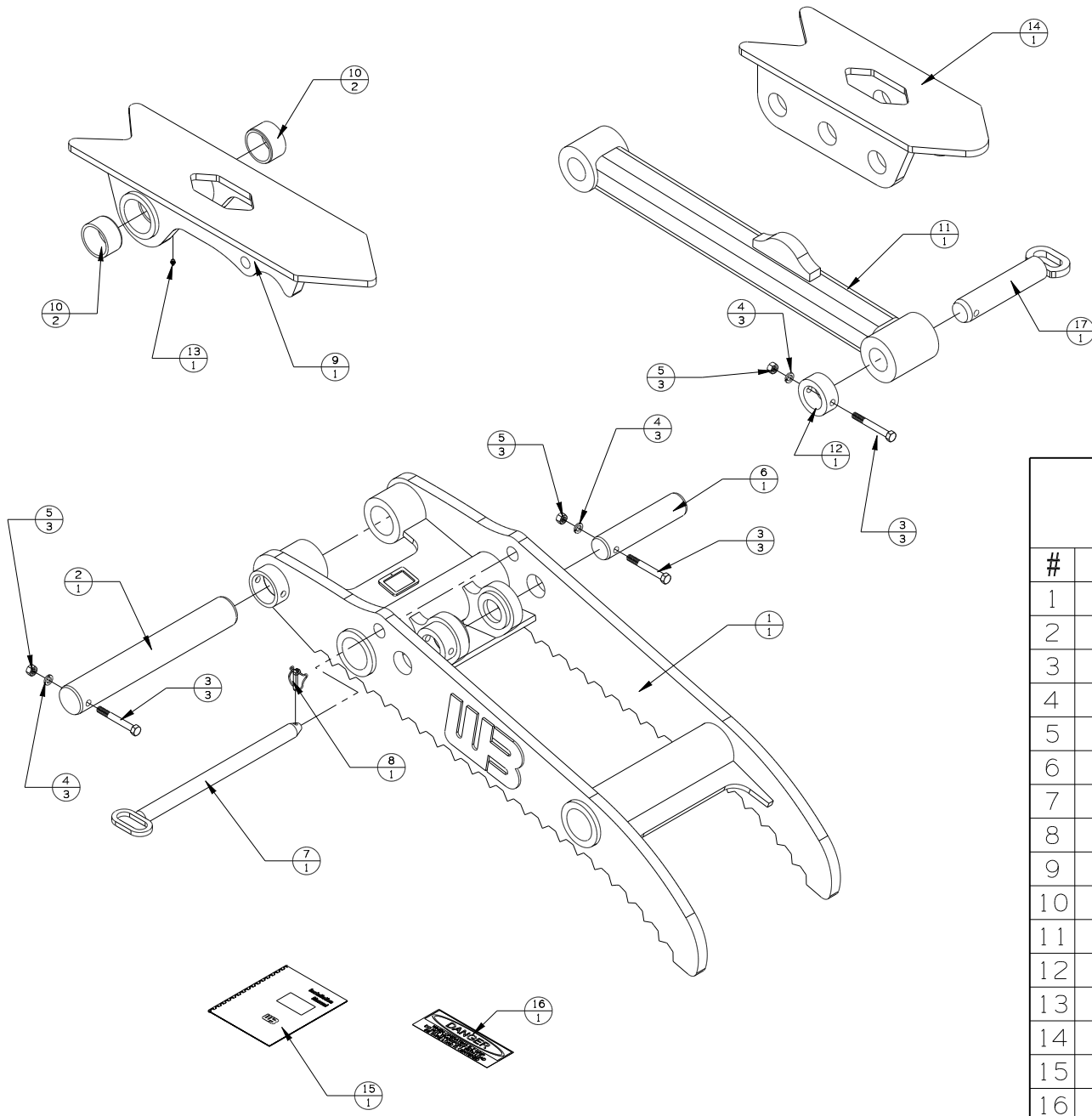

## EZRGEX1-M3-PACKLIST

#	DESCRIPTION	PART #	AMT
1	WELDED ASSEMBLY	EZRGEX1-M3-**	1
2	PIVOT PIN	PIN-0143	1
3	1/2-13 UNC X 4 1/2	13221	3
4	1/2 LOCK WASHER	33626	3
5	1/2-13 UNC NUT	36310	3
6	CYLINDER PIN	EZGPL-CP-9	1
7	LOCK PIN	PIN-0144	1
8	LINCH PIN	161397	1
9	PIVOT MOUNT (B)	EZRGEX1-TC-PMT	1
10	BUSHING	EZRGF11-4-TC-15	2
11	RIGID ARM	EZRGEX1-MKIII-ARM	1
12	PIN RETAINER	EZRGF11-4-TC-14	1
13	GREASE ZERK	60102	1
14	RIGID MOUNT	EZRGEX1-MKIII-RMT	1
15	INSTRCUTIONS	INST-EZRGF-B	1
16	STICKERS	D-DANGER-EZG	2
17	RIGID PIN	EZRGEX1-TC-08	1



**WERK-BRAU CO., INC.**  
 2800 FOSTORIA AVE. P.O. BOX 545 FINDLAY, OHIO 45840-0545  
 www.werkbrau.com PHONE: 419-422-2912 FAX: 419-422-7207

INCH 1/X: ± 1/16 X: ± 1.50  
 .X: ± .1 X.X: ± 0.80  
 .XX: ± .01 X.XX: ± 0.25  
 .XXX: ± .005 ANGLE ± 0.5°  
 .XXXX: ± .0005 NOT TO SCALE

WELD SPEC: WELDS TO CONFORM TO P7.PRO6-WB ARC WELDING QUALITY STANDARD

DATE: 2-6-18

WEIGHT: - Lbs.

MACHINE: -

PART No.: EZRGEX1-M3-PACKLIST

FILE NAME: EZRGEX1-M3-PACKLIST.CKD

THIS PRINT AND THE INFORMATION CONTAINED HERE ON IS A CONFIDENTIAL DISCLOSURE, THE SUBJECT MATTER OF WHICH IS THE PROPERTY OF: WERK-BRAU CO., INC.

DRAWN:

**B**  
REVISION

