

REV	DATE	CHANGE DESCRIPTION	BY	CHECKED
A	3-24-11	RELEASE FOR PRODUCTION	-	-
B	01-15-13	FIXED ARM GRIP PIN TO EZRGF10-4-TC-13	SJF	GJS
C	7-15-15	UPDATE CYLINDER TO 600-5333	JAS	-
-	-	-	-	-
-	-	-	-	-
-	-	-	-	-
-	-	-	-	-

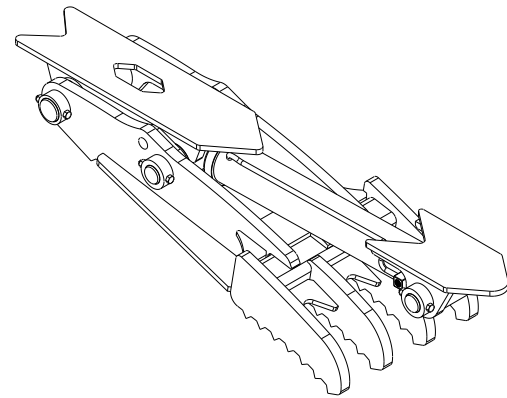
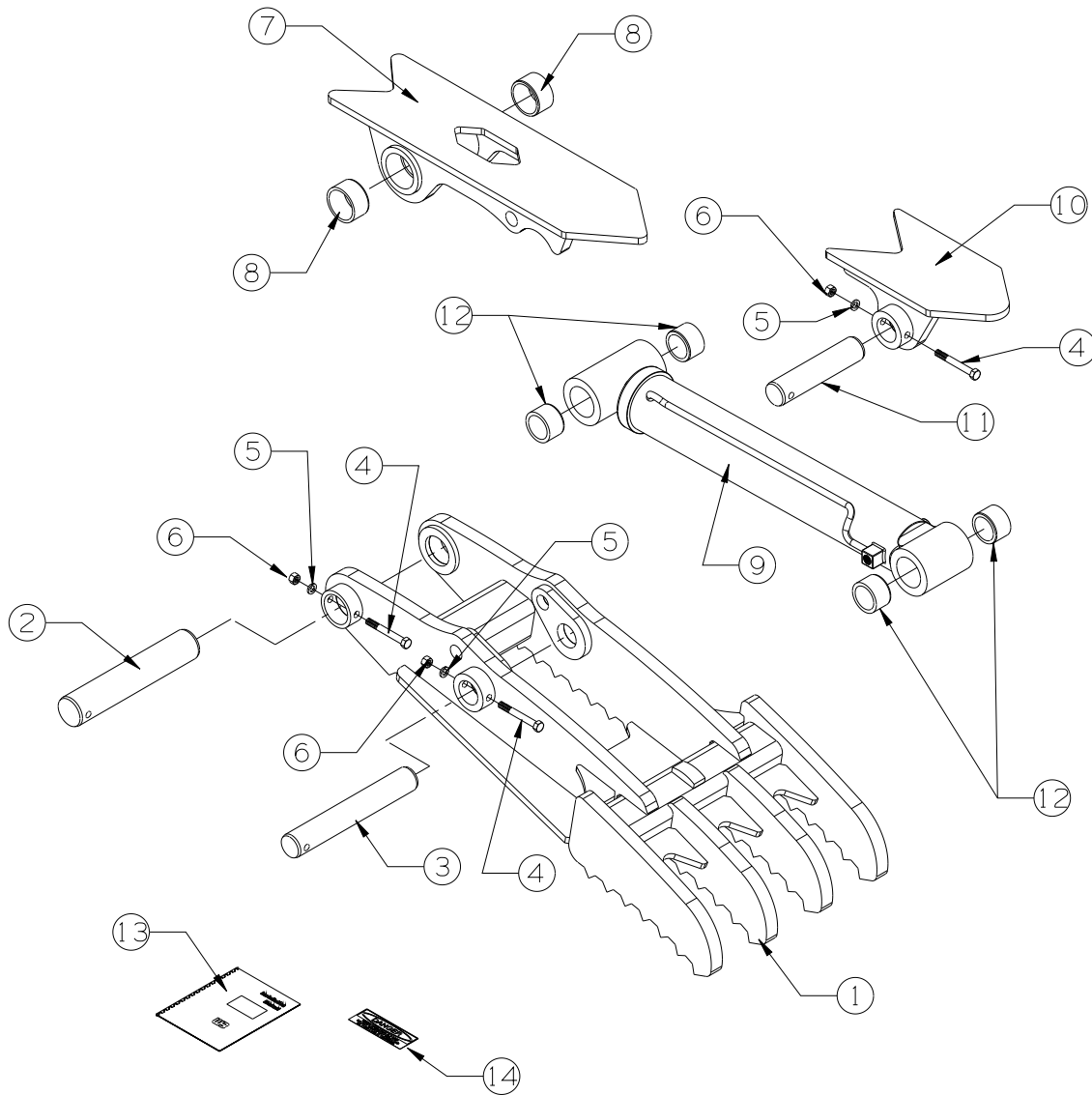

EZRGEX2-TC-H-PACKLIST

#	DESCRIPTION	PART #	AMT
1	WELDED ASSEMBLY	EZRGEX2-TC-***	1
2	PIVOT PIN	EZRGF10-30-07	1
3	ARM/GRIP PIN	EZRGF10-4-TC-13	1
4	5/8-11 UNC X 5 BOLT	13323	3
5	5/8 LOCK WASHER	33630	3
6	5/8-11 UNC NUT	36314	3
7	PIVOT MOUNT	EZRGEX2-TC-PMT	1
	ZERKS INSTALLED	Y/N	1
8	PIVOT BUSHINGS	EZRGF10-4-TC-15	2
9	CYLINDER	600-5333 C	1
	ZERKS INSTALLED	Y/N	2
10	CYLINDER MOUNT	EZRGEX2-TC-CMT	1
11	CYLINDER PIN	EZRGEX2-TC-19	1
12	CYLINDER BUSHINGS	EZRGF10-4-TC-16	4
13	INSTRUCTIONS	-	1
14	DANGER STICKER	-	2

**-SPECIFIES TIP RADIUS

REV. #
C

WB WERK-BRAU CO., INC.
 2800 FOSTORIA AVE. P.O. BOX 545 FINDLAY, OHIO 45840-0545
 www.werkbrau.com PHONE: 419-422-2912 FAX: 419-422-7207

INCH METRIC
 1X: ± 1/16 X: ± 1.50
 .X: ± .1 X.X: ± 0.80
 .XX: ± .01 X.XX: ± 0.25
 .XXX: ± .005 ANGLE ± 0.5°
 .XXXX: ± .0005 NOT TO SCALE

MACHINE: - DWG. NO.: EZRGEX2-TC-H-PACKLIST.CKD DRAWN: *gjs*
 PART No.: EZRGEX2-TC-H-PACKLIST DATE: 3-24-11 ORDER No/S.N.: -----/-----|1

THIS PRINT AND THE INFORMATION CONTAINED HERE ON IS A CONFIDENTIAL DISCLOSURE, THE SUBJECT MATTER OF WHICH IS THE PROPERTY OF: WERK-BRAU CO., INC.