

REV	DATE	CHANGE DESCRIPTION	BY	CHECKED
A	3-24-11	RELEASE FOR PRODUCTION	-	-
B	2-20-12	CHANGE CYLINDER TO 600-5302	JAS	-
-	-	-	-	-
-	-	-	-	-
-	-	-	-	-
-	-	-	-	-
-	-	-	-	-

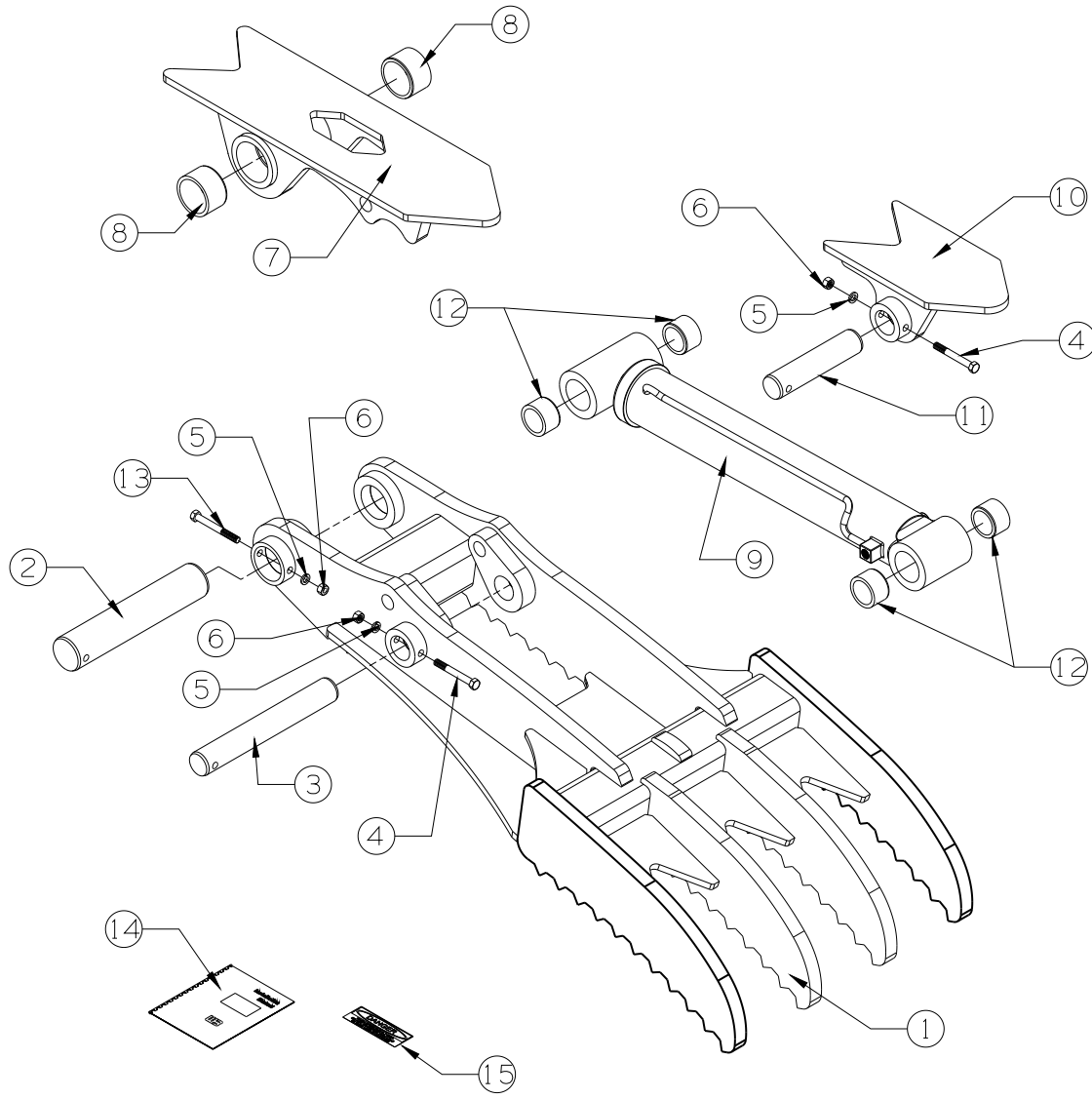

**--SPECIFIES TIP RADIUS

REV.#
B

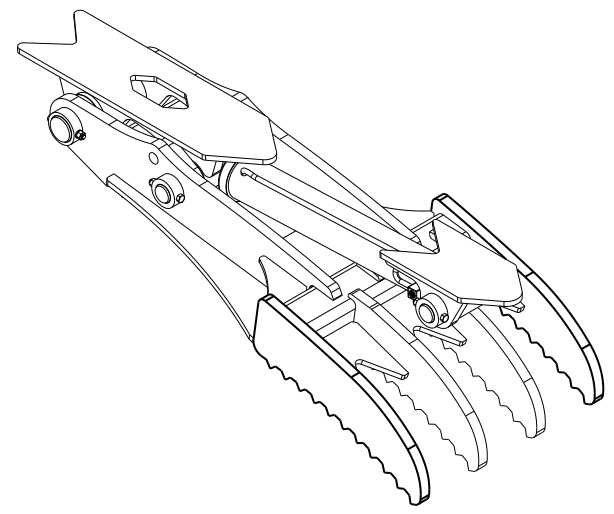

EZRGEX3-TC-H-PACKLIST

#	DESCRIPTION	PART #	AMT
1	WELDED ASSEMBLY	EZRGEX3-TC-***	1
2	PIVOT PIN	EZRGF7-32-08	1
3	ARM/GRIP PIN	EZRGEX3-TC-13	1
4	5/8-11 UNC X 5 BOLT	13323	2
5	5/8 LOCK WASHER	33630	3
6	5/8-11 UNC NUT	36314	3
7	PIVOT MOUNT	EZRGEX3-TC-PMT	1
	ZERKS INSTALLED	Y/N	1
8	PIVOT BUSHINGS	EZRGF10-4-TC-15	2
9	CYLINDER	\diamond 600-5302	1
	ZERKS INSTALLED	Y/N	2
10	CYLINDER MOUNT	EZRGEX2-TC-CMT	1
11	CYLINDER PIN	EZRGEX2-TC-19	1
12	CYLINDER BUSHINGS	EZRGF10-4-TC-16	4
13	5/8-11 UNC X 5 1/2 BOLT	13324	1
14	INSTRUCTIONS	-	1
15	DANGER STICKER	-	2



WERK-BRAU CO., INC.
 2800 FOSTORIA AVE. P.O. BOX 545 FINDLAY, OHIO 45840-0545
 www.werkbrau.com PHONE: 419-422-2912 FAX: 419-422-7207

INCH
 1/X: ± 1/16
 .X: ± .1
 .XX: ± .01
 .XXX: ± .005
 .XXXX: ± .0005

METRIC
 X: ± 1.50
 X.X: ± 0.80
 X.XX: ± 0.25
 ANGLE ± 0.5°
 NOT TO SCALE

MACHINE: -

DWG. NO.: EZRGEX3-TC-H-PACKLIST.CKD

DRAWN: *JAS*

PART No.: EZRGEX3-TC-H-PACKLIST

DATE: 3-24-11

ORDER No/S.N.: -----/-----|1

THIS PRINT AND THE INFORMATION CONTAINED HERE ON IS A CONFIDENTIAL DISCLOSURE, THE SUBJECT MATTER OF WHICH IS THE PROPERTY OF: WERK-BRAU CO., INC.