

REV	DATE	CHANGE DESCRIPTION	BY	CHECKED
A	10-20-14	RELEASE FOR PRODUCTION	-	-
-	-	-	-	-
-	-	-	-	-
-	-	-	-	-
-	-	-	-	-
-	-	-	-	-

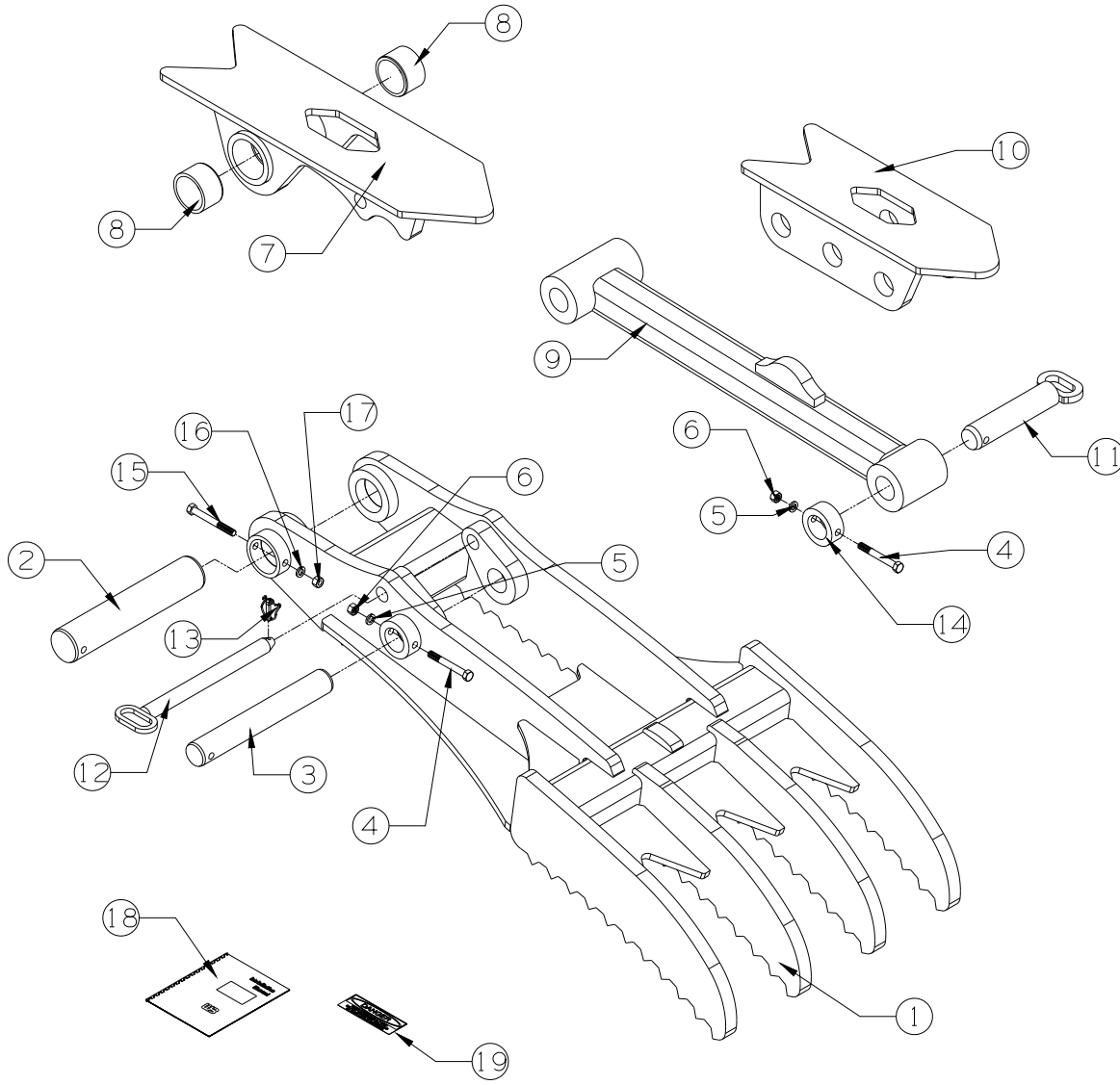

\*\*--SPECIFIES TIP RADIUS

REV. #  
**A**

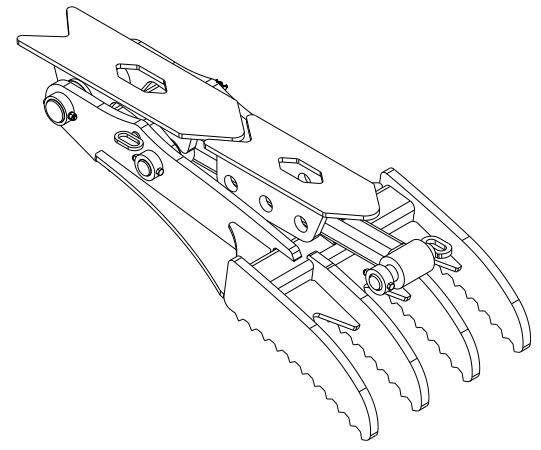

# EZRGEX3-TC2-PACKLIST

#	DESCRIPTION	PART #	AMT
1	WELDED ASSEMBLY	EZRGEX3-TC2-***	1
2	PIVOT PIN	EZRGF7-32-08	1
3	ARM/GRIP PIN	EZRGEX3-TC2-13	1
4	3/4-10 UNC X 5 1/2 BOLT	13374	2
5	3/4 LOCK WASHER	33632	2
6	3/4-10 UNC NUT	36316	2
7	PIVOT MOUNT	EZRGEX3-TC2-PMT	1
	ZERKS INSTALLED	Y/N	1
8	PIVOT BUSHINGS	EZRGF10-4-TC-15	2
9	RIGID ARM	EZRGEX3-TC2-RM	1
10	RIGID MOUNT	EZRGEX3-TC2-RMT	1
11	RIGID ARM PIN	EZRGEX3-TC2-08	1
12	LOCK PIN	EZRGEX3-TC-18	1
13	LYNCH PIN	161397	1
14	PIN RETAINER	PR-600	1
15	5/8-11 UNC X 5 1/2 BOLT	13324	1
16	5/8 LOCK WASHER	33630	1
17	5/8-11 UNC NUT	36314	1
18	INSTRUCTIONS	INST-EZRGF-A	1
19	DANGER STICKER	-	2

**WB WERK-BRAU CO., INC.**  
 2800 FOSTORIA AVE. P.O. BOX 545 FINDLAY, OHIO 45840-0545  
 www.werkbrau.com PHONE: 419-422-2912 FAX: 419-422-7207

INCH 1/16 X ± 1/16  
 .X ± .1  
 .XX ± .01  
 .XXX ± .005  
 .XXXX ± .0005  
 METRIC X ± 1.50  
 X.X ± 0.80  
 X.XX ± 0.25  
 ANGLE ± 0.5°  
 NOT TO SCALE

MACHINE: - DWG. NO.: EZRGEX3-TC2-PACKLIST.CKD DRAWN: PART No.: EZRGEX3-TC2-PACKLIST DATE: 3-24-11 ORDER No/S.N.: -----/-----|1

THIS PRINT AND THE INFORMATION CONTAINED HERE ON IS A CONFIDENTIAL DISCLOSURE, THE SUBJECT MATTER OF WHICH IS THE PROPERTY OF: WERK-BRAU CO., INC.