

REV	DATE	CHANGE DESCRIPTION	BY	CHECKED
A	1-28-16	RELEASED TO PRODUCTION	JAS	-
-	-	-	-	-
-	-	-	-	-

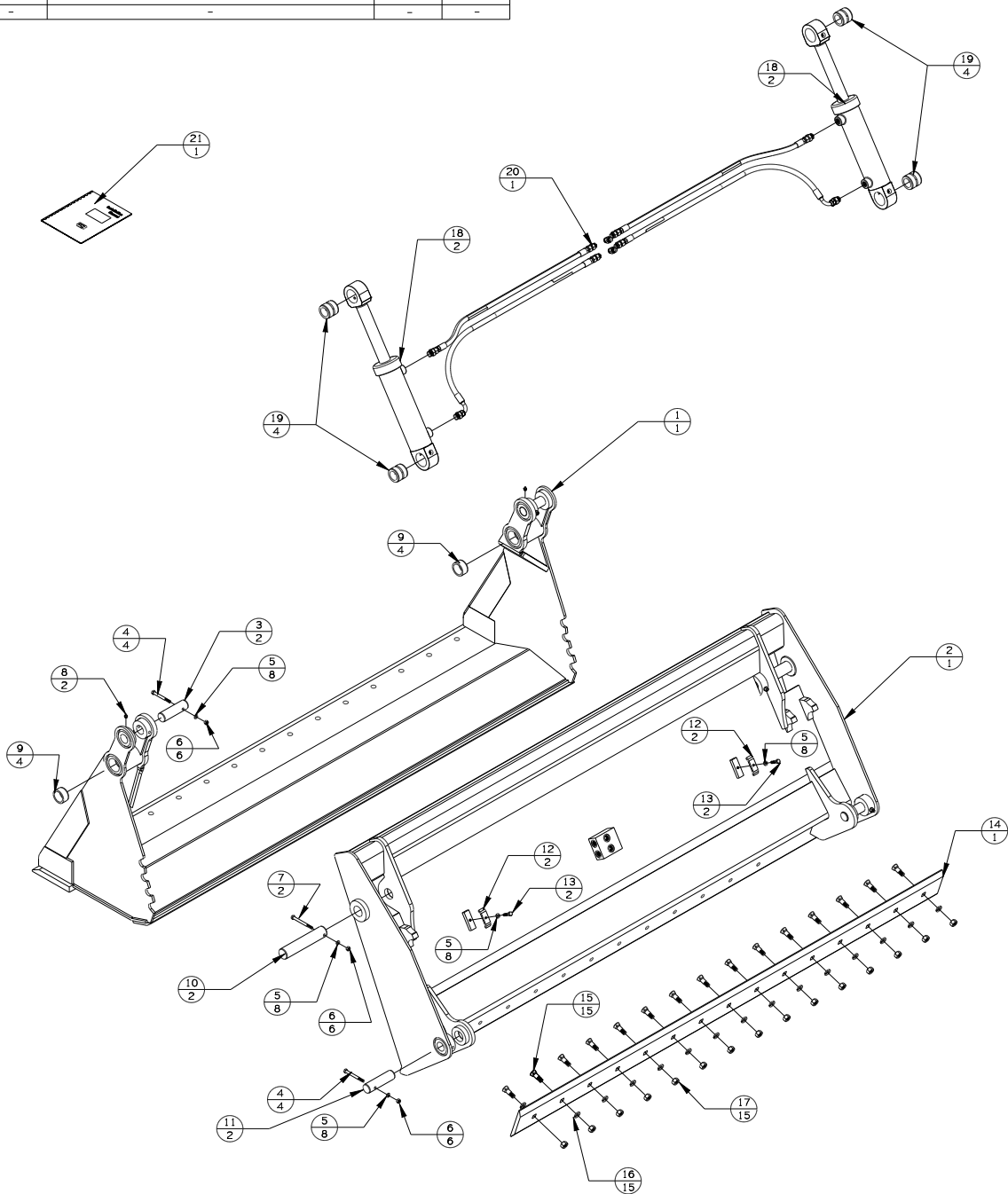

QB921L-PACKLIST

#	DESCRIPTION	PART #	AMT
1	CLAM	QB921L-CLAM	1
2	BLADE	QB921L-BLADE	1
3	PIN	QBWL-CP-2	2
4	3/8-16 UNC X 3 1/2	13117	4
5	3/8 LOCK WASHER	33622	8
6	3/8-16 UNC NUT	36306	6
7	3/8-16 UNC X 4	13119	2
8	GREASE ZERK	60102	2
9	BUSHING	QBWL-BP-1	4
10	PIN	QBWL-PP-1	2
11	PIN	QBWL-CP-1	2
12	HOSE CLAMP	D143846	2
13	3/8-16 UNC X 1 1/4	13107	2
14	BOLT ON EDGE	WBBCE-625X6-91.25	1
15	5/8 X 2 PLOW	22685	15
16	5/8 LOCK WASHER	33630	15
17	5/8-11 UNC NUT	36314	15
18	CYLINDER	600-4623	1
19	BUSHING	QBWL-BC-1	4
20	HOSE KIT	QB921L-HK	1
21	INSTRUCTIONS	INST-WL QUAD	1



WERK-BRAU CO., INC.
 2800 FOSTORIA AVE. P.O. BOX 545 FINDLAY, OHIO 45840-0545
 www.werkbrau.com PHONE: 419-422-2912 FAX: 419-422-7207

INCH 1/X: ± 1/16 X: ± 1.50
 .X: ± .1 X.X: ± 0.80
 .XX: ± .01 X.XX: ± 0.25
 .XXX: ± .005 ANGLE ± 0.5°
 .XXXX: ± .0005 NOT TO SCALE

WELD SPEC: WELDS TO CONFORM TO P7.PRO6-WB ARC WELDING QUALITY STANDARD

DATE: 1-28-16

WEIGHT: - Lbs.

MACHINE: -

PART No.: QB921L-PACKLIST

FILE NAME: QB921L-PACKLIST.CKD

THIS PRINT AND THE INFORMATION CONTAINED HERE ON IS A CONFIDENTIAL DISCLOSURE, THE SUBJECT MATTER OF WHICH IS THE PROPERTY OF: WERK-BRAU CO., INC.

DRAWN:

A
REVISION

