

REV	DATE	CHANGE DESCRIPTION	BY	CHECKED
A	9-15-15	RELEASED TO PRODUCTION	JAS	-
B	5-12-17	UPDATE TO NEW FLOW CONTROL	JAS	-
-	-	-	-	-

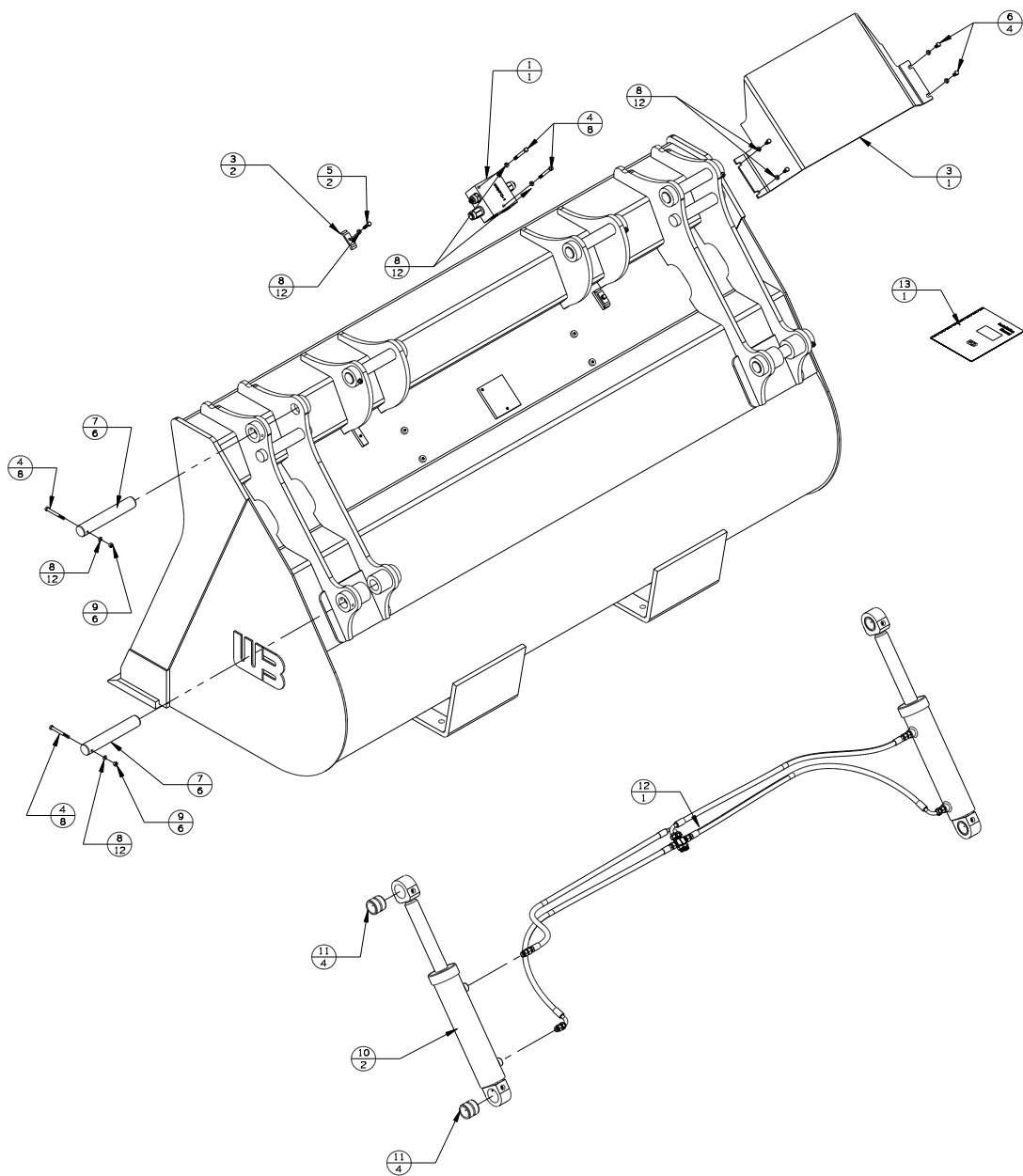

WL1GB88-PACKLIST

#	DESCRIPTION	PART #	AMT
1	FLOW CONTROL	(B) FV-12163-V2	1
2	HOSE CLAMP	D143846	2
3	SHROUD	14031080	1
4	3/8-16 UNC X 3 1/2	13117	8
5	3/8-16 UNC X 1 1/4	13107	2
6	3/8-16 UNC X 3/4	13103	4
7	PINS	WLGB-PP-2	6
8	3/8 LOCK WASHER	33622	12
9	3/8-16 UNC NUT	36306	6
10	CYLINDER	500010209	2
11	CYLINDER BUSHING	QBWL-BC-1	4
12	HOSE KIT	1GB88-STD-HK	1
13	INSTRUCTION MANUAL	INST-WL GRAPPLE	1

WB WERK-BRAU CO., INC.
 2800 FOSTORIA AVE. P.O. BOX 545 FINDLAY, OHIO 45840-0545
 www.werkbrau.com PHONE: 419-422-2912 FAX: 419-422-7207

INCH 1/X: ± 1/16
 .X: ± .1
 .XX: ± .01
 .XXX: ± .005
 .XXXX: ± .0005
 METRIC X: ± 1.50
 X.X: ± 0.80
 X.XX: ± 0.25
 ANGLE ± 0.5°
 NOT TO SCALE

WELD SPEC: WELDS TO CONFORM TO P7.PRO6-WB ARC WELDING QUALITY STANDARD

DATE: 12-7-15

WEIGHT: - Lbs.

MACHINE: -

PART No.: WL1GB88-PACKLIST

FILE NAME: WL1GB88-PACKLIST.CKD

B
REVISION

THIS PRINT AND THE INFORMATION CONTAINED HERE ON IS A CONFIDENTIAL DISCLOSURE, THE SUBJECT MATTER OF WHICH IS THE PROPERTY OF: WERK-BRAU CO., INC.

DRAWN:

