



EXTENDABLE MAIN PIN BACKHOE THUMB

CASE 580SV / NEW HOLLAND B95D

PRODUCT MANUAL & INSTALLATION KIT

THANK YOU FOR YOUR PURCHASE You have received a high quality, extremely versatile attachment that will increase your machine's capability. The multi-purpose is a versatile-durable tool. This attachment increases the tasks a single machine can perform; reducing the number of dedicated task machines needed on a job site.

TELL US WHAT YOU THINK Werk-Brau would like to know what you think about its products. Please visit our website & share your experience with us!

**PRODUCT MANUAL
&
INSTALLATION KIT**



**WERK-BRAU Co.,
Inc.**

2800 FOSTORIA AVE.
FINDLAY, OH 45840

WWW.WERK-BRAU.COM

YOUR PARTNER IN PRODUCTION

IMPORTANT This instruction manual describes the installation, operation, and maintenance for a Werk-Brau attachment. Please take the time to record the information listed below.

Serial No.: _____

Model No.: _____

Date Manufactured: _____

ABOUT WERK-BRAU Since 1947, Werk-Brau has manufactured the highest quality and most innovative specialty products for the heavy equipment industry. Werk-Brau is respected internationally for providing outstanding customer service and being dedicated to excellence in all aspects of our business. Duke Werkheiser and Dutch Brautigam, for whom the company is named after, first opened their blacksmith shop in Findlay Ohio. Still today Werk-Brau manufactures and produces in Findlay Ohio, in a state of the art facility.

Over the decades Werk-Brau has grown and become so much more than a simple blacksmith operation. Today Werk-Brau proudly employs an industry leading team of professionals who work hard to follow the vision set by the founders of Werk-Brau to "Provide Excellence in Customer Service". As a modern company Werk-Brau is efficient, high-tech, dedicated to its customers, and deeply proud of the quality of products manufactured.

Werk-Brau manufactures a complete line of O.E.M. and replacement attachments for excavators, mini excavators, backhoes, mini and full size loaders and crawler loaders. All over the world Werk-Brau attachments can be found hard at work in the toughest of conditions.

THANK YOU FOR YOUR PURCHASE!

WORK SAFE

STOP!!!

Do not proceed further without fully understanding this page

Before welding an attachment or operating any attachment, clearance checks must be made. This means cautiously putting the machine and attachment through all movements. This is at the responsibility of the attachment installer. In some cases clearance issues are unavoidable so the operator must be made aware prior to operating the machine. If your attachment did not come with a decal for this possible interference, please contact your Werk-Brau representative to help assist. Werk-Brau is not responsible for clearance issues or damaged caused by attachment interference.

For all hydraulic attachments, ensure that the machines pressure is at the recommended setting. See pg. 12 for pressure setting details.

SAFETY STATEMENT GUIDE



→ Danger tags are used in major hazard situations where an immediate hazard presents a threat of death or serious injury to operator and anyone about.



→ Warning tags are used to represent a hazard level between “Caution” and “Danger”, instead of the required “Caution” tag, provided that they have a signal word of “Warning,” an appropriate major message.



→ Caution tags are used in minor hazard situations where a non-immediate or potential hazard or unsafe practice presents a lesser threat of injury.



→ A notice label is used where equipment or property damage could result if the instructions are not followed properly.



→ This symbol by itself or used with a safety signal word throughout this manual is used to call your attention to instructions involving your personal safety or the safety of others. Failure to follow these instructions can result in injury or death.

GENERAL SAFETY PRECAUTIONS



READ MANUAL PRIOR TO INSTALLATION Improper installation, operation, or maintenance of this equipment could result in serious injury or death. Operations and maintenance personnel should read this manual as well as manuals related to equipment and the operating



READ AND UNDERSTAND ALL SAFETY STATEMENTS Read all safety decals and safety statements in all manuals prior to operating or working on the equipment. Know and obey all OSHA regulations, local laws and other professional guidelines for your operation. Know and follow good work practices when assembling, maintaining, repairing, mounting, removing or operating this equipment.



KNOW YOUR EQUIPMENT Know your equipment’s capabilities, dimensions and operations before operating. Visually inspect your equipment before you start, and never operate equipment that is not in proper working order with all safety devices intact. Check all hardware to assure it is tight. Make certain that all locking pins, latches, and connection devices are properly installed and secured. Remove and replace any damaged, fatigued or excessively worn parts. Make certain all safety decals are in place and are legible. Keep decals clean, and replace them if they become worn and hard to read.



PROTECT AGAINST FLYING DEBRIS Always wear proper safety glasses, goggles with a face shield when driving pins in or out or when any operation causes dust, flying debris, or any other hazardous material.



LOWER OR SUPPORT RAISED EQUIPMENT Do not work under raised booms without supporting them. Do not use support material made of concrete blocks, logs, buckets, barrels or any other material that could suddenly collapse or shift positions. Make sure support material is solid, not decayed, warped, twisted, or tapered. Lower the boom(s) to ground level or onto block(s). Lower the boom(s) and attachment(s) to the ground before leaving the cab or operator’s station.



USE CARE WITH HYDRAULIC FLUID PRESSURE Hydraulic fluid under pressure can penetrate the skin and cause serious injury or death. Hydraulic leaks under pressure may not be visible.

Before connecting or disconnecting hydraulic hoses, read your operating machines operator’s manual for detailed instructions on connecting and disconnecting hydraulic hoses or fittings.

- Keep unprotected body parts, such as face, eyes, and arms as far away as possible from a suspected leak. Flesh

injected with hydraulic fluid may develop gangrene or other permanent disabilities. Wear safety glasses, protective clothing, and use a sound piece of cardboard or wood when searching for hydraulic leaks. **DO NOT USE YOUR HANDS!**

- If injured by injected fluid, see a doctor at once. If your Doctor is not familiar with this type of injury, ask him to research immediately to determine proper treatment.



DO NOT MODIFY MACHINE OR ATTACHMENTS Modifications may weaken the integrity of the attachment and may impair the function, safety, life and performance of the attachment. When making repairs, use only the manufacturer's genuine parts, following authorized instructions. Other parts may be substandard in fit and quality. For loaders, never modify any ROPS (Roll Over Protection System) equipment or device. **ANY MODIFICATIONS MUST BE AUTHORIZED IN WRITING BY THE WERK-BRAU OR THE MANUFACTURER.**



SAFELY OPERATE THE EQUIPMENT Do not operate equipment until you are completely trained by a qualified operator in how to use the controls, know its capabilities, dimensions, and all safety requirements. See your operating machines manual for these instructions.



- Keep all step plates, grab bars, pedals, and controls free of dirt, grease, debris, and oil.
- Be sure that all bystanders are out of harms way when operating.
- Do not allow riders on the attachment or operating machine
- Do not operate the equipment from anywhere other than the correct operators position.
- Never leave equipment unattended with the engine running or with this attachment in a raised position.
- Do not alter or remove any safety feature from the operating machine or this attachment.
- Know your work site safety rules as well as traffic rules and flow. When in doubt on any safety issue, contact your supervisor or safety coordinator for an explanation.



SAFELY MAINTAIN AND REPAIR EQUIPMENT

- Do not wear loose clothing, or any accessories that can catch in moving parts. If you have long hair, cover or secure it so that it does not become entangled in the equipment.
- Work on a level surface in a well-lit area.
- Use properly grounded electrical outlets and tools.
- Use the correct tool for the job at hand. Make sure tools are in good condition.
- Wear all protective equipment specified by the tool manufacturer.

OPERATING PRECAUTIONS



DO NOT IMPROPERLY USE ATTACHMENT This coupler is designed to grab objects and debris and not for any other use.



BE AWARE OF SURROUNDING UTILITIES Operator must be aware of all utility line and overhead electrical lines. Operations must be able to clear all lines safely.



BE AWARE OF OVERHEAD DANGER Operator must be aware of all possible overhead dangers that are within the range of motion of the operating machine.



DO NOT OPERATE WITH A LOOSE ATTACHMENT Visually check the coupler to verify attachments are secure and lock is fully engaged and that the center to center of the attachment matches the up with the coupler.



PINCH POINTS Personal injury could result from the careless misuse of this coupler. Keep hands and body parts clear of the coupler when it's in the process of hooking up to an attachment. Be sure the machine is off and the attachment is on the ground prior to making adjustments.

TORQUE SPECIFICATIONS

Please observed these approved specs. Failure to observe these specs can result in damage and other undesirable results.

Dash Size	Tube O.D. (Ref)	Thread Size	Torque Values Ft. Lbs.			
			37° Flare		Straight Thread	
			Ft. Lbs.	Nm.	Ft. Lbs.	Nm.
4	1/4	7/16-20	10-12	14-16	15-19	20-25
5	5/16	1/2-20	13-16	18-21	20-25	27-33
6	3/8	9/16-18	20-25	27-33	32-40	45-54
8	1/2	3/4-16	34-42	46-56	54-67	73-90
10	5/8	7/8-14	46-58	62-78	74-92	100-124
12	3/4	1-1/16-12	64-80	87-108	102-128	138-173
14	7/8	1-3/16-12	80-100	109-135	128-160	173-216
16	1	1-5/16-12	97-117	131-158	150-187	203-253
20	1-1/4	1-5/8-12	145-165	197-223	227-264	308-357
24	1-1/2	1-7/8-12	230-250	312-338	363-400	492-542

**Apply enough pipe sealer to contact all threads.*

***Do not use that excess will squeeze into the hydraulic lines.*

HYDRAULIC INSTRUCTIONS

ALWAYS BE SURE TO DOUBLE CHECK HYDRUALICS Make sure all hydraulic lines and fittings are tight and secure before starting the machine. In the event of a hydraulic problem or failure, discontinue use of the attachment immediately.

STORAGE

- Clean the unit thoroughly, removing all mud, dirt, and grease.
- Inspect for visible signs of wear, breakage, or damage. Order any parts required and make the necessary repairs to avoid delays upon removal from storage.
- Tighten loose nuts, cap screws and hydraulic connections.
- Coat exposed portions of the cylinder rods with grease.
- Lubricate grease fittings.
- Seal hydraulic system from contaminants and secure all hydraulic hoses off the ground to help prevent damage.
- Replace decals that are damaged or in unreadable condition.
- Store unit in a dry and protected place. Leaving the unit outside will materially shorten its life. Additional

PRECAUTIONS FOR LONG TERM STORAGE

- Touch up all unpainted surfaces with paint to prevent rust. REMOVAL FROM STORAGE
- Remove cover.
- Wash unit and replace any damaged and/or missing parts.
- Lubricate grease fittings.
- Check hydraulic hoses for damage and replace as necessary.

MAINTENANCE AND SERVICE

Procedure	Daily	Every 40 Hrs
Check all bolts and nuts for tightness	X	
Replace any missing bolts or nuts with approved replacement parts	X	
Check hydraulic system for hydraulic oil leaks. See procedure below.	X	
Visually inspect the machine for worn parts or cracked welds, and repair as necessary.	X	
Lubricate all grease fittings		X

OIL CLEANLINESS REQUIREMENTS All hydraulic fluid shall be filtered before use in any FFC product to obtain the ISO cleanliness standard of 20/18/15. Unless explicitly specified otherwise.

FITTINGS/HOSES INSPECTION GUIDELINES Stop the prime mover engine and release hydraulic pressure before servicing or adjusting hydraulic system.

WARNING Escaping fluid under pressure can have sufficient force to penetrate the skin, causing serious personal injury. Fluid escaping from a very small hole can be almost invisible. Use a piece of cardboard or wood, rather than hands, to search for suspected leaks.

Keep unprotected body parts, such as face, eyes, and arms as far away as possible from a suspected leak. Flesh injected with hydraulic fluid may develop gangrene or other permanent disabilities.

If injured by injected fluid, see a doctor at once. If your doctor is not familiar with this type of injury, ask him to research it immediately to determine proper treatment.

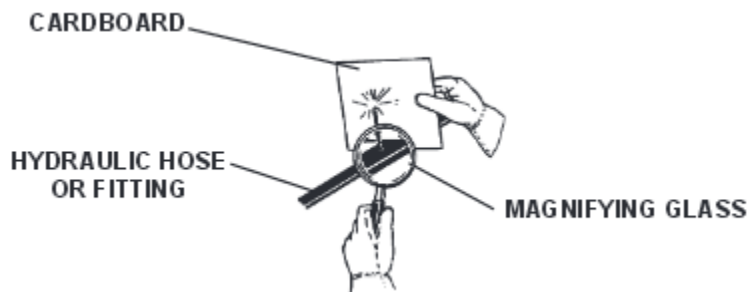

IMPORTANT When replacing parts, use only factory approved replacement parts. Manufacturer will not claim responsibility for use of unapproved parts or accessories, and/or other damages as a result of their use.

QUESTIONS

For replacement parts, questions, and other matters please call your local dealer. If you cannot reach a local dealer please call and we will be happy to find a dealer for you and answer any questions.

WELD INSTRUCTIONS

Disclaimer: This "Welding Guide" is designed to give recommended welding guidelines for the application of mounting a Werk-Brau grip for our valued customers. It is a general welding guide and is not all inclusive. Each customer application may require special welding practices. Werk-Brau accepts no responsibility for the misuse or misinterpretation of this information. It is the responsibility of the customer to have the weld process installation of the thumb assembly comply with the latest version of *AWS D14.3/D14.3M-Specification for Welding Earthmoving, Construction, and Agricultural Equipment* and *ANSI Z49.1-Safety in Welding, Cutting, and Allied Processes*.

- Workmanship requirements for all arc welding processes:
 - Only qualified personnel and procedures should be used when performing the welding during installation.
 - The surfaces to be welded will be free of moisture, paint, loose or thick scale, slag, heavy rust, grease or oil, or any other foreign material which could adversely affect the structural integrity of the finished weld.
 - No welding shall be performed within 1/2" (13mm) minimum of paint or any other heavy contamination.
 - Welding shall not be performed when the weldment is exposed to high winds, drafts, or moisture.
 - Welding shall not be performed when the temperature of the part(s) is lower than 50°F (10°C).
 - Arc strikes outside of the joint must be ground off.
 - Minimum fillet weld leg size, including root passes for multi-pass welds, shall not be smaller than 3/16" (5mm).
 - Maximum fillet weld leg size deposited in one pass shall not exceed 5/16" (8mm).
 - Allow all welds to naturally cool in still ambient air. Do not quench or air cool.
 - Weld joint gaps should not exceed 1/8" (3mm). Gaps exceeding 1/8" (3mm), that cannot be corrected, should have the weld size increased to include the gap measurement.

- Processes:

Welding should be done by any or combination of the following processes:

 - Shielded Metal Arc Welding (SMAW)
 - Gas-Metal Arc Welding (GMAW)
 - Metal-Cored Arc Welding (MCAW)
 - Flux-Cored Arc Welding (FCAW)

➤ Recommended filler metal:

The following filler metal should be used but are not limited to:

Process	AWS Specification	AWS Classification
SMAW*	AWS A5.1	E7015, E7016, E7018
GMAW	AWS A5.18	ER70S-X
MCAW	AWS A5.18	E70C-XX (except -GS)
FCAW	AWS A5.20	E7XT-X(M) (except -2, -3, -10, -13, -14, or -GS)

*Special care should be taken to ensure that low hydrogen electrodes are properly conditioned.

➤ Shielding gas:

Shielding gas for GMAW, MCAW, and FCAW-G should be of welding grade quality complying with the latest edition of *AWS A5.32/5.32M Specification for Welding Shielding*.

➤ Electrical characteristics:

- All welding should be done using direct current reverse polarity (DC+)
- Filler metal manufacturer's recommended welding parameters and variables should be followed.
- Voltage and amperage range for GMAW, MCAW, and FCAW should be sufficient enough to produce a spray, or globular transfer. Short-circuit transfer is not recommended.

➤ Position:

All welding should preferably be done in a flat or horizontal position.

➤ Fillet Weld Size:

Fillet weld sizes detailed on the installation instructions are metric and given as leg size (shown below). Weld size can deviate slightly but shall not exceed $-0.5/+3\text{mm}$.

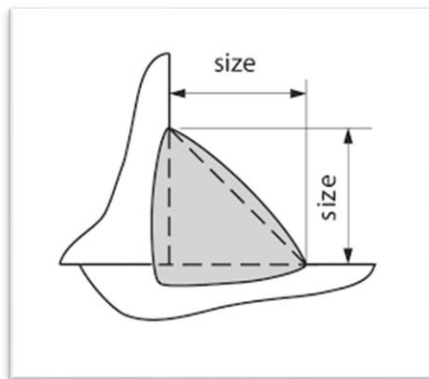

Reference Pictures

AUX hose brackets: (see step 10 from installation guide for location detail & pg. 8 above for welding requirements)



P-CLAMP HOSE RETAINER, ONE ON EACH SIDE: (see “auxiliary extension kit” detail on following pages)



AUXILIARY PRESSURE ADJUSTMENT

This thumb will require the bi-aux circuit. This circuit uses a section in the main backhoe valve and the pressure relief valves are in that section. The pressure relief valves are on the back side of the backhoe. If you face the rear of the machine, the adjustments are on the far-left side underneath the cab. You may have to remove taper proof caps from the adjustment screws. To lower pressure, turn adjustment screws counterclockwise – to increase pressure, turn adjustment screws clockwise.

This thumb attachment will require 2250 PSI. Use pressure gauges when testing auxiliary pressure to ensure accurate pressure reading. If pressure exceeds the recommended setting, damage may occur to your hydraulic cylinder or thumb pins.

Note: remove plastic guard just under the rear window for better access to adjustment screws.



INSTALLATION GUIDE ON THE FOLLOWING PAGES

STEP 1

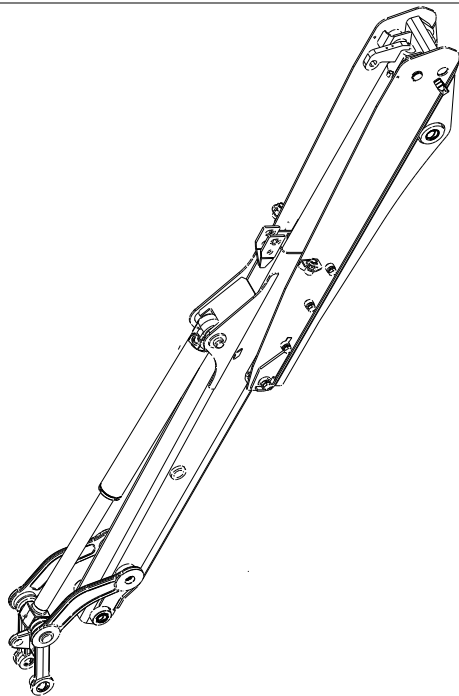

1. EXTEND THE BOOM ALL THE WAY OUT

STEP 2

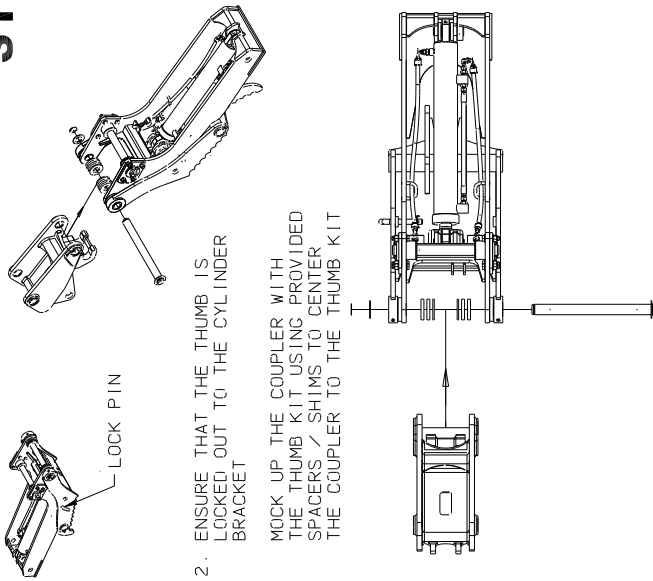

2. ENSURE THAT THE THUMB IS LOCKED OUT TO THE CYLINDER BRACKET
 LOCK UP THE COUPLER WITH THE THUMB KIT USING PROVIDED SPACERS / SHIMS TO CENTER THE COUPLER TO THE THUMB KIT

STEP 3

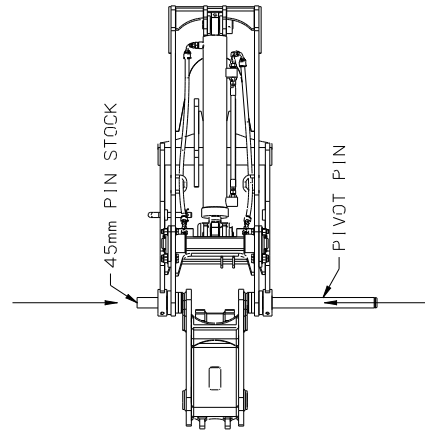

3. FEED THE PIVOT PIN THROUGH ONE SIDE OF THE THUMB, THUMB BRACKET & COUPLER EARS
 NOTE - USE A 45mm PIN TO FEED THROUGH THE OPPOSITE SIDE TO ALIGN THE THUMB KIT & COUPLER LEAVING THE CENTER OF THE COUPLER OPEN FOR THE END OF THE DIPPER STICK

STEP 4

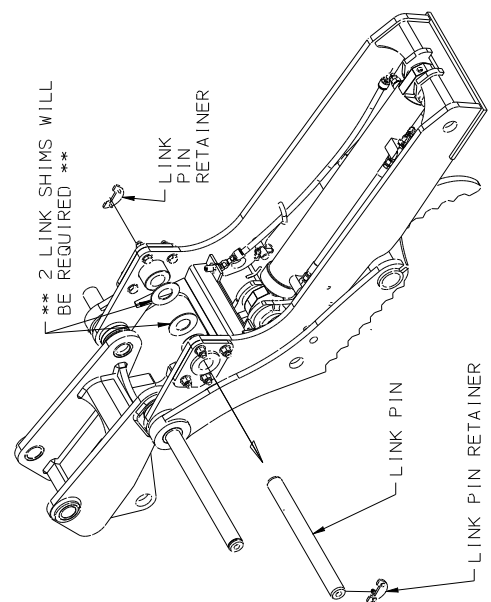

** 2 LINK SHIMS WILL BE REQUIRED **

4. REMOVE THE LINK PIN RETAINERS & LINK PIN FROM THUMB KIT TO PREP FOR MACHINE INSTALL

STEP 5

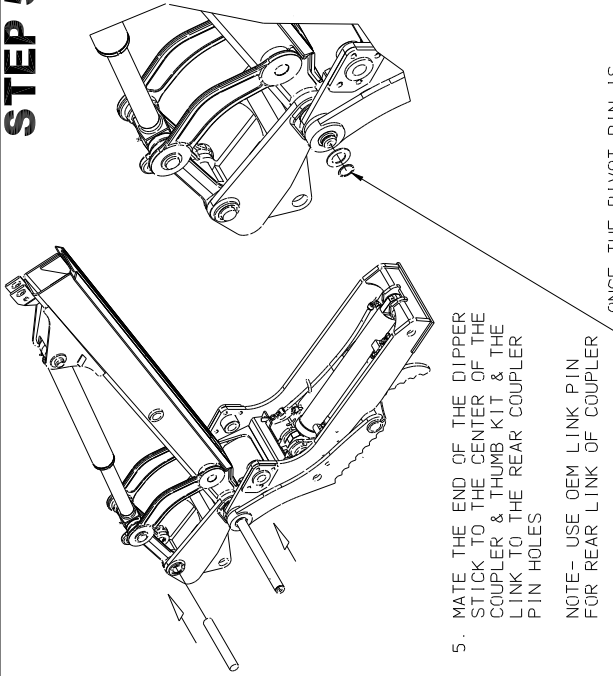

5. MATE THE END OF THE DIPPER STICK TO THE CENTER OF THE COUPLER & THUMB KIT & THE LINK TO THE REAR COUPLER PIN HOLES
 NOTE- USE OEM LINK PIN FOR REAR LINK OF COUPLER

ONCE THE PIVOT PIN IS INSTALLED, APPLY SPACER & SNAP RINGS ON EACH END OF THE MAIN PIVOT PIN

STEP 6

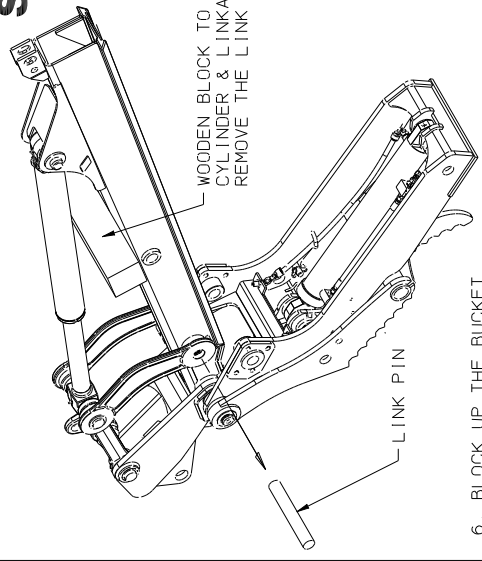

6. BLOCK UP THE BUCKET CURL CYLINDER & REMOVE FACTORY LINK PIN FROM DIPPER STICK.
 NOTE- YOU MUST BLOCK UP THE BUCKET CURL CYLINDER SO THAT THE LINK & CYLINDER DO NOT COLLAPSE ONCE THE LINK PIN IS REMOVED

STEP 7

7. WITH THE CYLINDER SUPPORTED, HOIST THE THUMB KIT UP TO THE DIPPER STICK

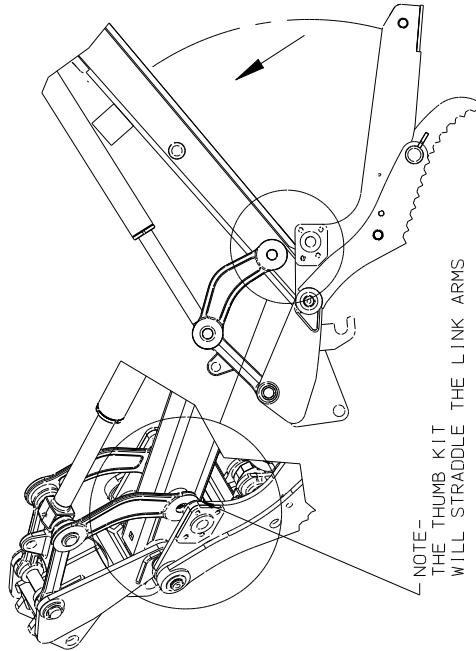

NOTE- THE THUMB KIT WILL STRADDLE THE LINK ARMS

STEP 8

EXPLODED VIEW OF LINK PIN

- ALIGN MILLED SLOT PARALLEL WITH THE TAPPED HOLES ON THE FACE OF THE OUTER BOSSES

SLIDE RETAINER INTO PLACE & BOLT TO THE BOSS FACE USING PROVIDED 1/4"-20 BOLTS & WASHERS

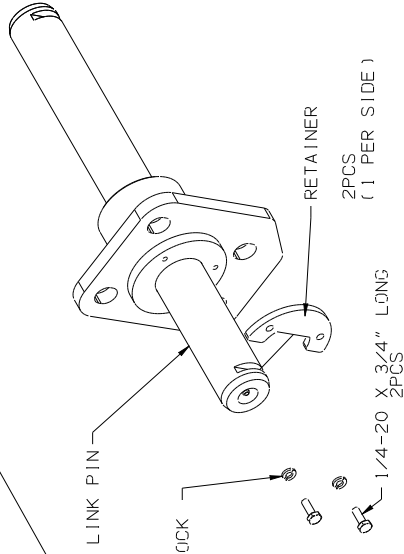

8. WITH THUMB KIT CENTERED TO LINKAGE PIN HOLE, LOOSEN THE (8) 5/8" BOLTS NOTED "A"

THEN FEED THE NEW LINK PIN THROUGH THE THUMB BRACKET, LINK ARMS & DIPPER STICK

MAKE SURE TO INCLUDE 1/8" SHIMS BETWEEN LINK ARMS & THUMB BRACKET TO TAKE UP ALL GAPS

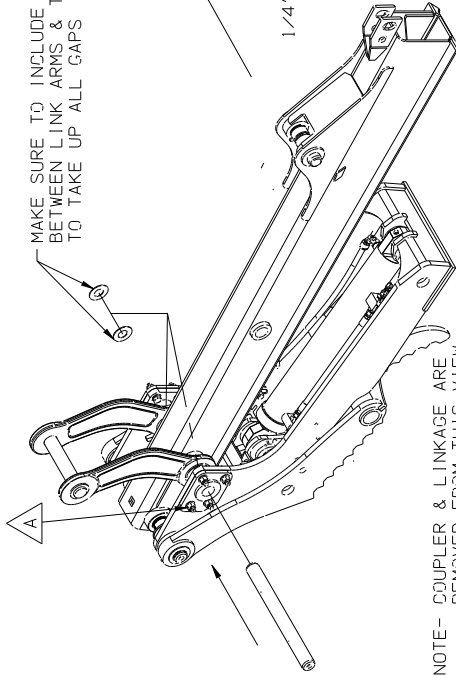

NOTE- COUPLER & LINKAGE ARE REMOVED FROM THIS VIEW FOR CLARITY

STEP 9

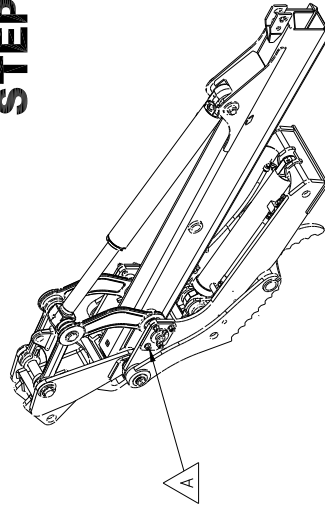

9. WITH LINK PIN IN PLACE & RETAINED, TIGHTEN ALL (8) 5/8" BOLTS & LOCK NUTS "A"

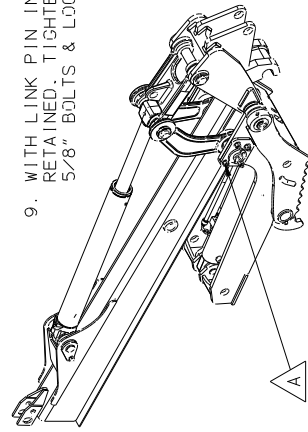

STEP 10

10. WELD PROVIDED BRACKETS TO DIPPER STICK. ONE ON EACH SIDE. 6mm FILLET WELD ALL AROUND

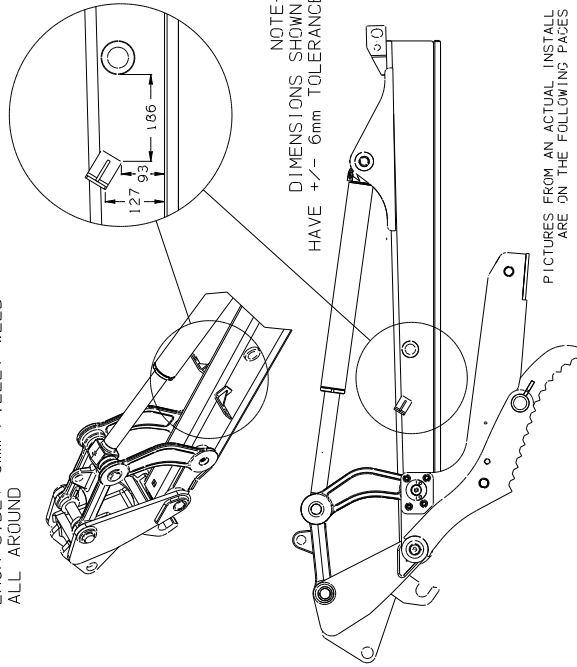

NOTE- DIMENSIONS SHOWN HAVE +/- 6mm TOLERANCE

PICTURES FROM AN ACTUAL INSTALL ARE ON THE FOLLOWING PAGES. PAINT THE BRACKETS CASE POWER TAN TO MATCH THE DIPPER STICK

STEP 11

11. COMPLETE THUMB KIT INSTALLATION BY PLUMBING THE HYDRAULIC HOSES & FITTINGS

NOTE- THE BI-DIRECTIONAL AUXILIARY SETTINGS MUST BE ADJUSTED ON THE MACHINE VALVE FOR PROPER THUMB OPERATION

SEE ADDITIONAL PAGES FOR MORE DETAILS FOR HYDRAULIC HOSE & FITTING ROUTING, & PRESSURE ADJUSTMENT

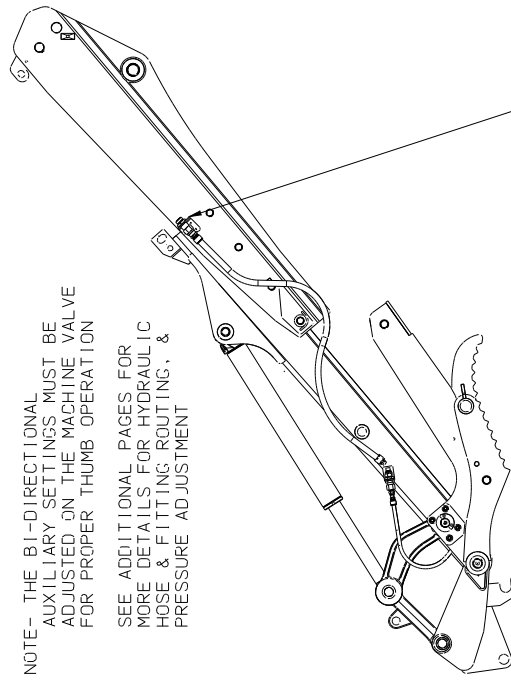

EXISTING AUX PORT ON STATIONARY DIPPER STICK

AUXILIARY EXTENSION KIT P/N EZG-5303-15-AUX-HK

#	DESCRIPTION	PART NUMBER	AMT
1	BULKHEAD LOCK NUT	FF306-12	2
2	BULKHEAD ADAPTER	FF2700-12-12	2
3	3/4" HOSE w/ NYLON SLEEVE	N/A	2
4	HOSE RETAINER TAB	12006069	2

SEE NEXT PAGE FOR HYDRAULIC KIT DETAIL
TO TIE IN THUMB HYDRAULICS TO MACHINE AUX

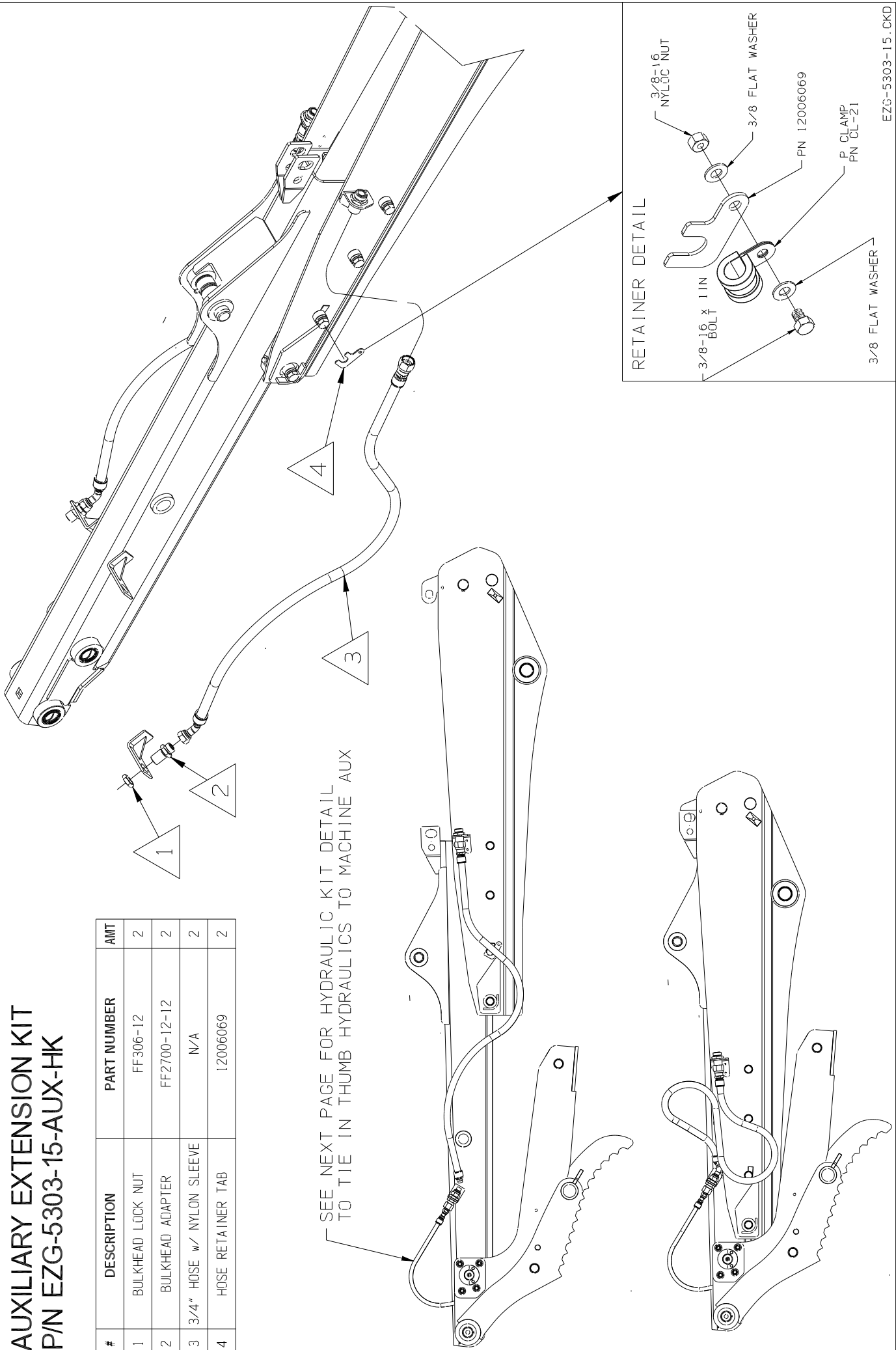

**AUXILIARY JUMPER KIT
P/N EZG-5303-15-CY-JK**

#	DESCRIPTION	PART NUMBER	AMT
1	REDUCER	FF2406-12-8	2
2	3/8" HOSE	N/A	2

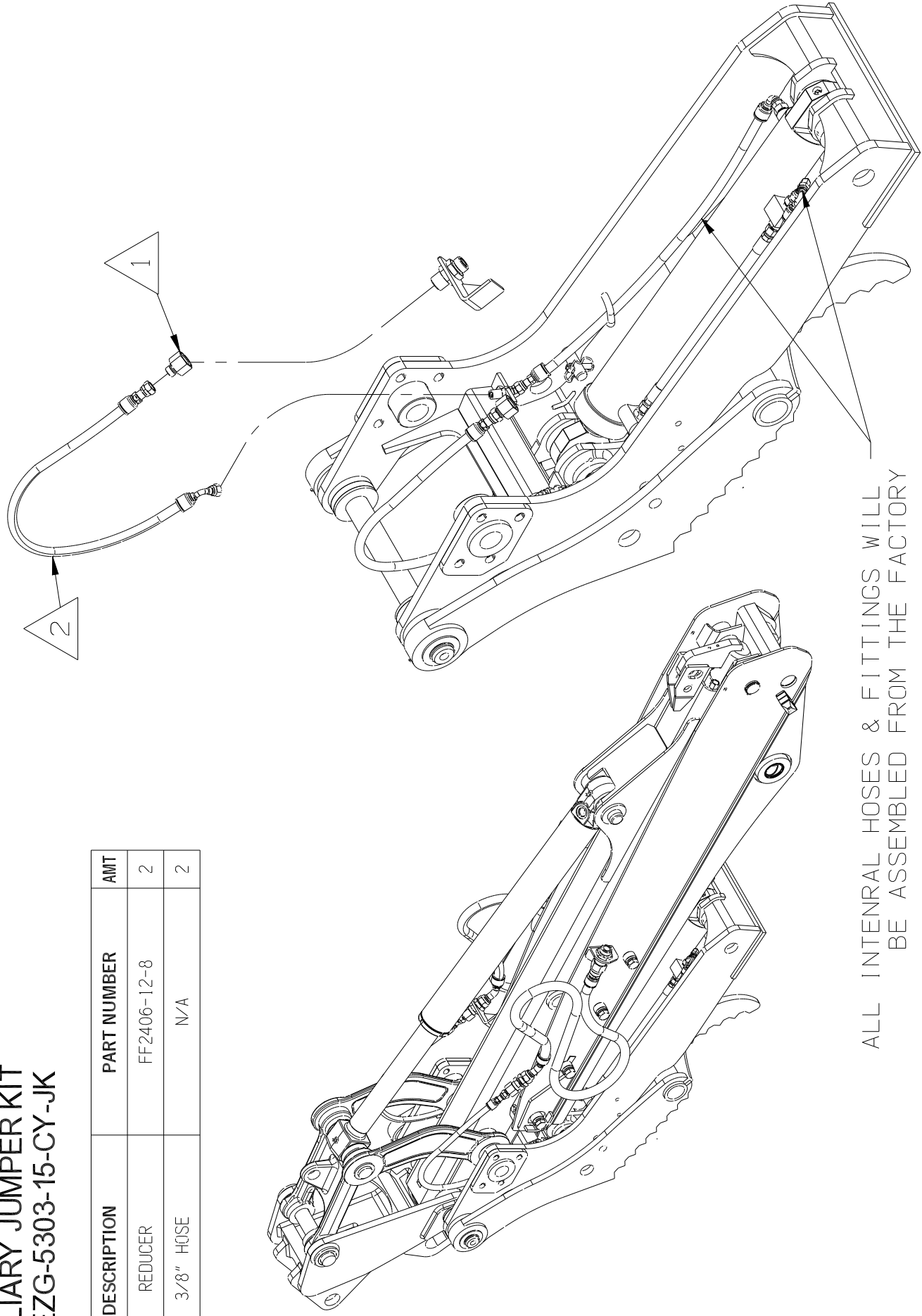

ALL INTERNAL HOSES & FITTINGS WILL
BE ASSEMBLED FROM THE FACTORY