

40EX-HD BRUSH SHREDDER

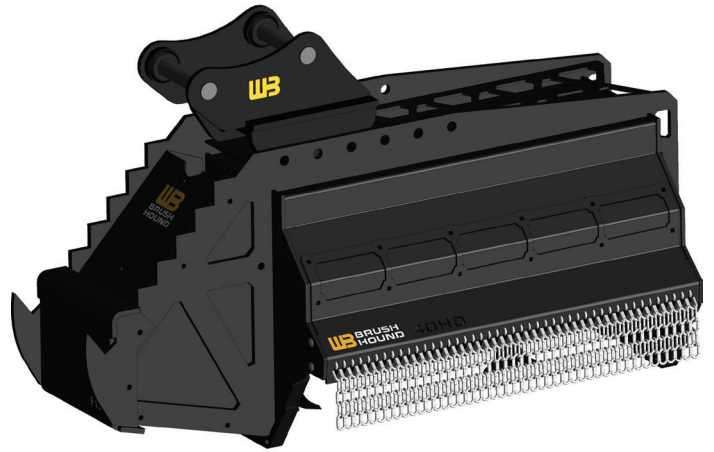

PRODUCT DESCRIPTION:

When maximum brush clearing is the goal, the 40EX-HD Brush Shredder is the robust tool of choice for professionals. It can safely and quickly turn a tree, brush pile, or woody area to mulch in minutes. The 40EX-HD transforms backhoes and excavators into powerful shredders and long-reach boom mowers. Cutting capacity .5-5".

PERFORMANCE:

The BrushHound 40EX-HD is built tough for the toughest jobs. It weighs 1,170 pounds, has a heavy-duty single-piece frame, a half-inch thick cutter drum and end plates that are 3/8" thick. It has a standard piston motor to adapt to high-pressure power units. It uses the innovative triple-flail knife design available on BrushHound EX series mowers.

40EX-HD Specifications

Model #	40EX-HD
Power Unit Size	16,000 - 24,000 lbs.
Cutting Width	40"
Overall Width	67"
Weight	1,170 lbs.
Number of Knives	24-Slicer 12-Center
Brush Capacity	5"
Hydraulic Flow Required	25-54 GPM
Motor Type	Piston

KEY FEATURES

- **High-Performance Cutter Drum:** More power for tougher tasks.
- **Extra-Strength Thumb Saddle:** Serrated edge works with excavator thumb to grab and remove debris or obstacles.
- **Bolt-on Excavator Mount:** Every model includes excavator-specific mount.
- **Adaptability:** Most compact excavators or backhoes 16,000 to 24,000 pounds.
- **Piston Motor:** Standard for high pressure power units.
- **Composite Dampener Washer:** Isolates operational vibration and increases drive component lifespan
- **Wire Guards:** Anti-wrap design protects bearings and seals from debris.
- **True Shaft Technology:** An electronically balanced cutter drum with serviceable hubs to ensure straight shafts that run smooth for years of reliable, vibration-free operation.
- **Triple Flail Knives:** Reversible triple knife 2.25-pound side slicer knives plus a 2-pound straight knife.
- **Bolt-on Chain Guards:** Easily replaceable if damaged.
- **Direct Drive Design:** Maximizes power transfer to cutter drum.
- **SAE Compliant:** Exceeds all SAE J1001 standards for flail mowers.
- **HD, Single-Piece Frame:** Increases strength without adding weight.
- **Hoses and Couplers:** 100" Hydraulic hoses and flat face couplers are complementary.
- **Case Drain Required**

