



ACTUATOR POWER ATTACHMENTS

HYDRA-CLAMP BUCKET & RAKE

Confidently handle heavy, awkward loads, grab buckets of debris and clear away brush with the Hydra-clamp Bucket and Rake. The built-on rotary actuated thumb provides improved flexibility and precision by maintaining consistent clamping force on the load throughout the entire bucket rotation.

KEY FEATURES:

- + Easy, low cost installation. Nothing needs welded to the stick
- + Heavy duty design makes perfect for demolition, picking/sorting applications and land clearing
- + Easily transferable from machine to machine makes perfect for a rental fleet
- + Powered by a fully enclosed rotary actuator
- + Increased holding strength versus standard thumb and bucket
- + Operator can use 100% of excavator reach
- + Thumb maintains strong grip on material throughout rotation
- + Easier to load trucks
- + Quick and easy install compared to standard thumb
- + Just two auxiliary hydraulic lines required
- + Very low maintenance
- + Less weight at the end of the stick versus standard bucket and thumb = more productivity
- + Made of high quality T-1 and AR400 materials in all high stress & wear areas
- + Plastic covering on thumb to protect the stick
- + Hydra-Clamp is available in bucket, rake and skeleton rock versions



**SCAN HERE
TO LEARN MORE**

PROUDLY MADE IN
FINDLAY
OHIO 

POWERGRIP BUCKET

PowerGrip® can be used as a trenching, grading or clamshell bucket with precise control and up to 120 degrees of jaw movement

KEY FEATURES:

- + 120 degrees of jaw movement
- + Constant operating speed
- + Holding force approximately 3x that of a standard hydraulic thumb
- + Powered by a fully enclosed rotary actuator
- + No exposed cylinders
- + Ability to grade, grapple and dig makes for great versatility
- + Very low maintenance
- + Just two auxiliary hydraulic lines required
- + Easy to install and transfer from one machine to another
- + No welding required



SCAN HERE
TO LEARN MORE



ACTUATOR-TILT DITCHING BUCKET

Instead of tilt cylinders, Werk-Brau offers their tilting grade bucket with a rotary actuator to achieve more tilting range of motion, tilting force, and also less downtime and maintenance.

KEY FEATURES:

- + Tilt any bucket up to 90 degrees each way (180 degrees total) vs. 45 degrees each way of a cylinder design
- + No exposed cylinders = less downtime
- + Productivity can increase by up to 50% by simply tilting your attachments
- + Tilting function is powered by a fully enclosed rotary actuator
- + Improved tilt holding force
- + Actuator tilt bucket design eliminates minimum width constraints like a typical cylinder version

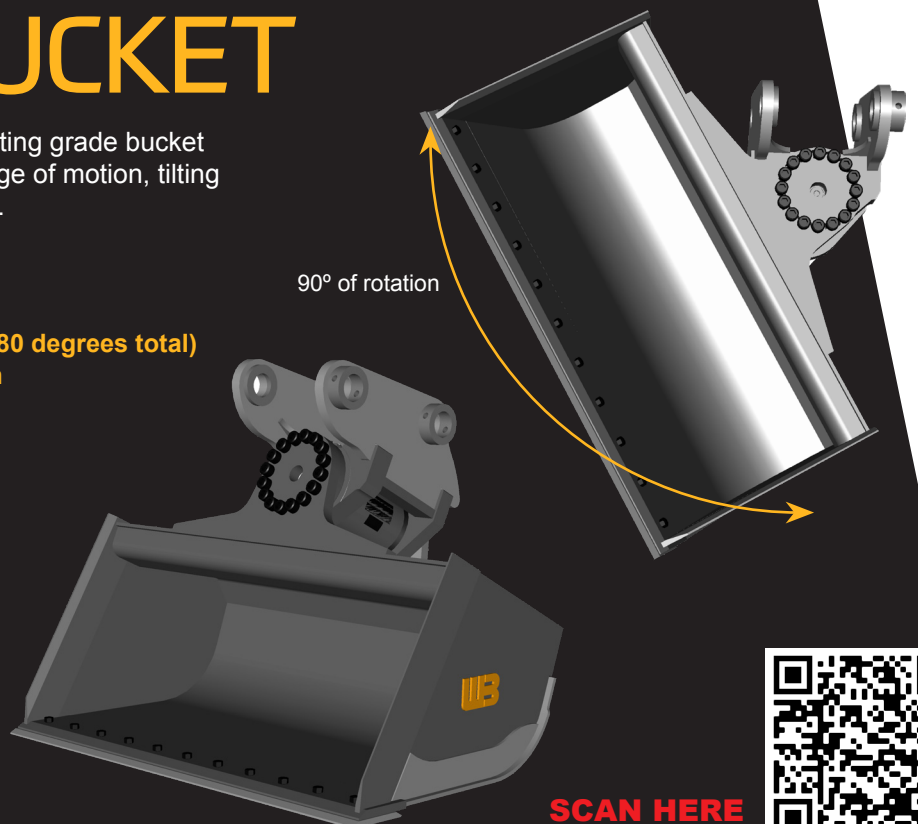

90° of rotation

SCAN HERE
TO LEARN MORE



POWER-TILT COUPLER

When productivity is paramount

The D-Lock Tilt has been designed with a compact and narrow body for better visibility and performance, giving it serious benefits over other brands. The D-Lock Tilt allows operators to simply tilt all attachments rather than having to move the entire machine, improving the productivity and versatility of the machine resulting in increased profits.

Mated with our rugged, triple-sealed power actuator, the D-Lock Tilt Coupler is built for virtually maintenance-free and trouble-free performance.

KEY FEATURES:

- + Integral overload protection
- + Simplified connections and controls
- + Fully guarded hoses
- + No unwanted movement
- + Up to 180 degrees of tilt
- + Compact design – Improving performance
- + No pins or bushings to wear out
- + Only requires four hydraulic lines

MODELS

D-LOCK TILT

MANUAL PIN GRAB TILT

MANUAL PULL-PIN (HALF HITCH)

WEDGE STYLE TILT

BANTAM STYLE TILT

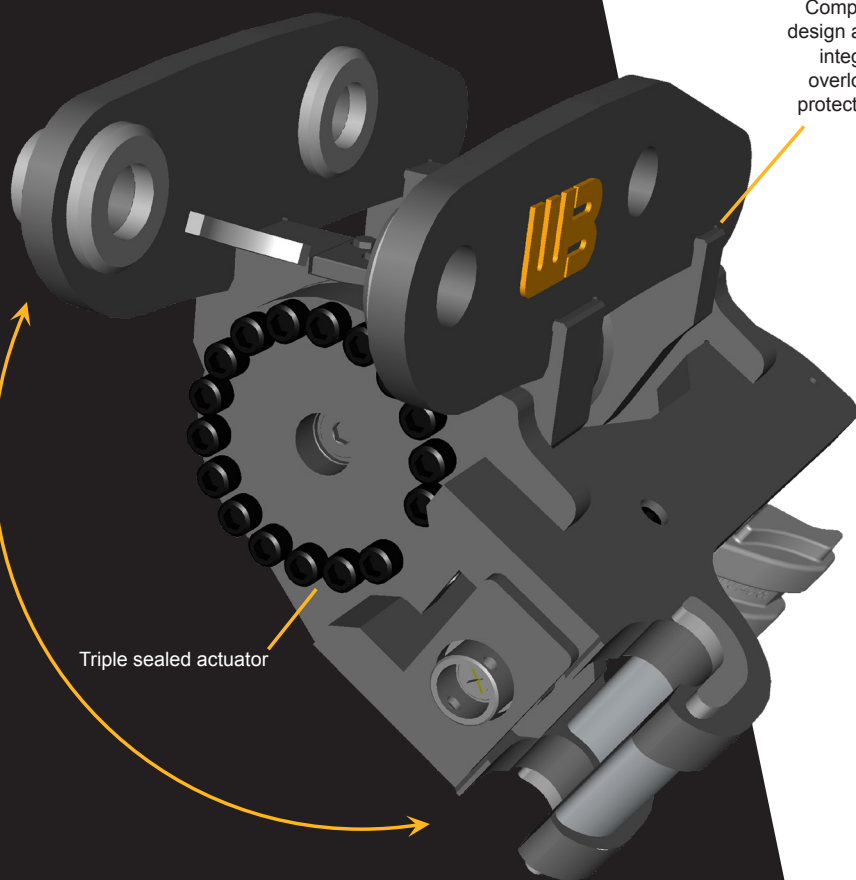

up to 180°
of tilt

Triple sealed actuator

Compact
design and
integral
overload
protection



SCAN HERE
TO LEARN MORE



For a list of dealers
or more information:

Werk-Brau.com
1-800-537-9561

419-422-7207 fax
2800 Fostoria Avenue
Findlay, OH 45840 USA