



WB[®]
WERK-BRAU

For a list of dealers
 or more information:

Werk-Brau.com
1-800-537-9561

419-422-7207 fax
 2800 Fostoria Avenue
 Findlay, OH 45840 USA

WB
WERK-BRAU

**EXCAVATOR
 BUCKETS**

PRODUCTION CLASS BUCKETS



HEAVY DUTY BUCKET - STANDARD VERTICAL SHROUDS

- Oversized, reinforced channel assembly for superior strength
- Single bottom
- Wear straps included
- Double vertical wear shrouds shown - standard
- High-grade steel used throughout all high wear areas
- Available from 55 to 125 tons (E55 to E125 series)



HEAVY DUTY BUCKET - OPTIONAL SIDE CUTTERS

- Oversized, reinforced channel assembly for superior strength
- Single bottom
- Wear straps included
- Single vertical shrouds
- Bolt-on side cutters shown - optional
- High-grade steel used throughout all high wear areas
- Available from 55 to 125 tons (E55 to E125 series)



SEVERE DUTY BUCKET - STANDARD VERTICAL SHROUDS

- Oversized, reinforced channel assembly for superior strength
- Double bottom
- Wear straps included
- Increased lip thickness and GET
- Double vertical wear shrouds shown - standard
- High-grade steel used throughout all high wear areas
- Available from 55 to 125 tons (E55 to E125 series)



EXTREME DUTY BUCKET

- Oversized, reinforced channel assembly for superior strength
- Double bottom
- Wear straps included
- Internal liner included
- Increased lip thickness and GET
- Double vertical wear shrouds shown - standard
- Heel shrouds included
- Segments between teeth shown
- High-grade steel used throughout all high wear areas
- Available from 55 to 125 tons (E55 to E125 series)

DEEPER BUCKET LIP

- E55 series & larger buckets have a 20% increase in depth to the bucket edge which is engineered for better stress flow and structure for the high-capacity design of the new buckets
- Stacked side cutter over outside adapter comes standard for added strength



THREE-PIECE TOP EAR REINFORCEMENT

- The multi-piece hanger reinforcement is designed to strengthen this high-stress area of the bucket. The center plate between the ears is shorter than the outer plates allowing for pin grabber coupler clearance. On the outsides of the ears, the plating is taller to support high stress loads on the ears



DOUBLED VERTICAL SIDE CUTTER SHROUDS INCLUDED FOR ALL HD/SD/ED BUCKETS

- E55 series & larger buckets are paired with solid side cutters, the included vertical shrouds provide added protection for over 90% of the bucket side cutter faces
- Optional lower bolt-on side cutters available upon request



T-1 EARS & RE-DESIGNED CHANNEL ASSEMBLY OR "TORQUE BEAM"

- The bucket ears are made of high-quality T-1 steel which are now paired with an enlarged channel assembly increasing the strength considerably in the top assembly of the bucket.
- An oversized lower beam paired with a multi-piece upper beam encompasses the bucket ears, which prevents flexing and torsion in this high-stress area increasing the life of the bucket.

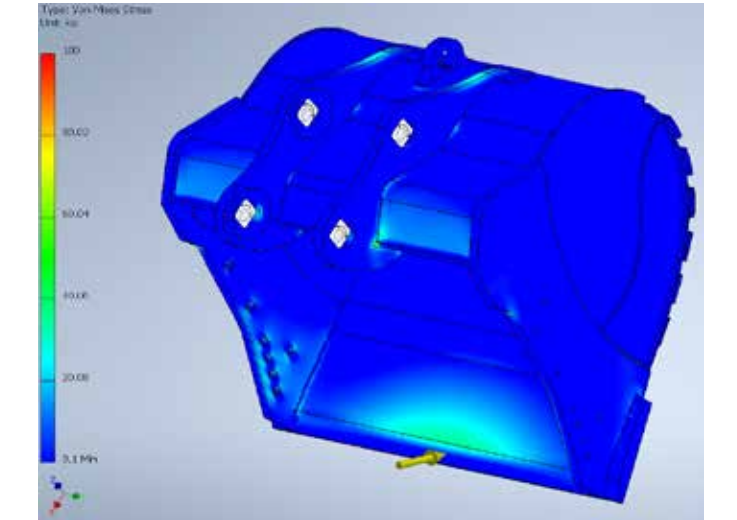

FEA TESTING

- Each bucket was FEA tested with advanced engineering analysis, especially in regards to breakout force
- The results yielded little stress in the typical high stress areas of an excavator bucket
- All buckets exceeded the stress test results proving out the longevity of our bucket design

