

REV	DATE	CHANGE DESCRIPTION	BY	CHECKED
A	4-20-18	RELEASED TO PRODUCTION	JAS	-
B	6-28-18	CHANGED CYLINDER PIN	TGS	-
C	5/18/22	UPDATED SHELL CALLOUT / UPDATE HOSE KIT	JGM	-

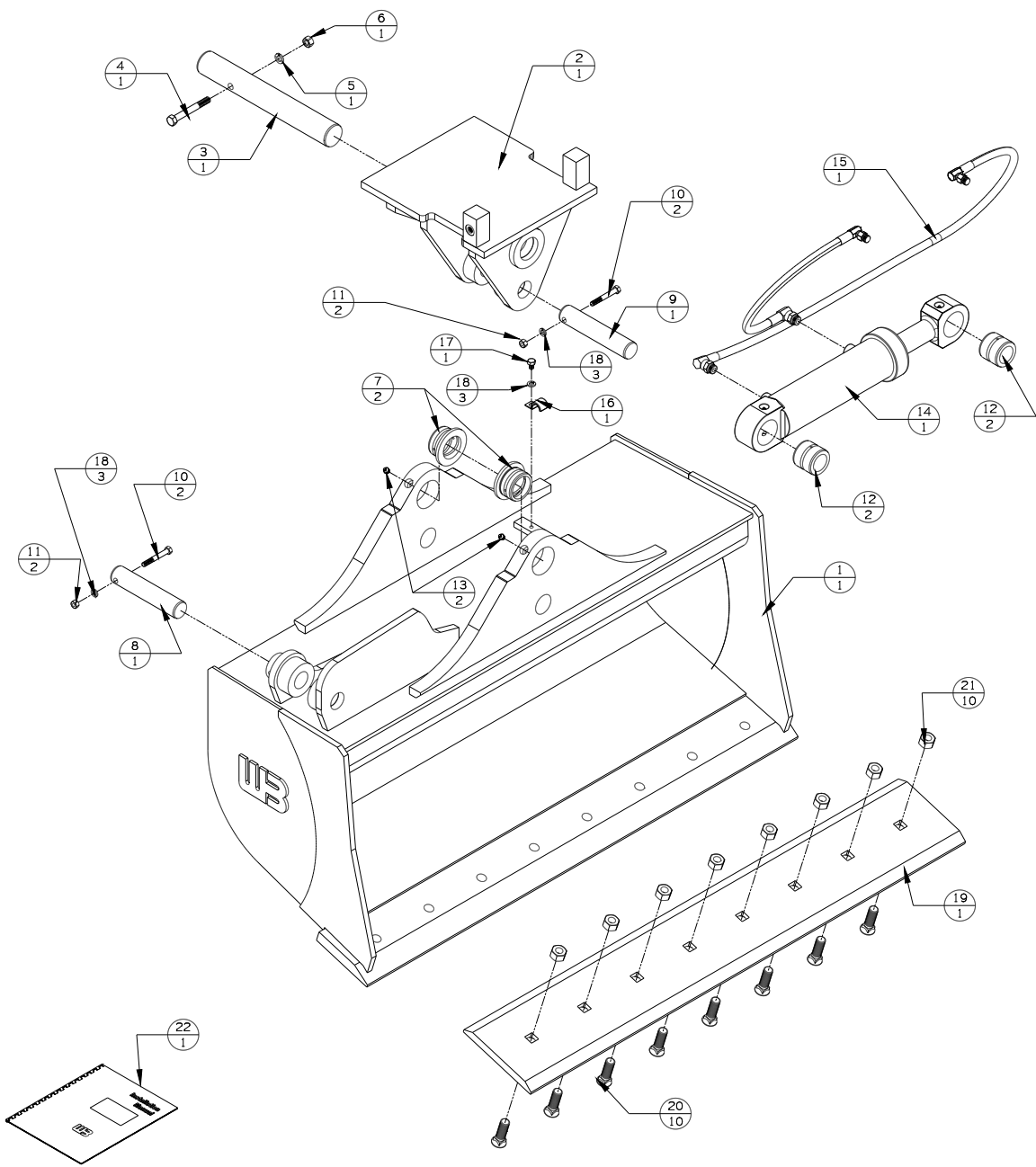

WTB5-60

#	DESCRIPTION	PART #	AMT
1	WELDED ASSEMBLY	WTB60-15.7(B/S)	1
2	TILT TOP	TIB-TI-03C	1
3	PIVOT PIN	TIB-PP-08	1
4	1/2-13 X 4 BOLT	13207	1
5	1/2 LOCK WASHER	33626	1
6	1/2-13 UNC NUT	36310	1
7	PIVOT BUSHING	TIB-BP-06	2
8	CYLINDER PIN	TIB-CP-04	1
9	CYLINDER PIN	TIB-CP-04	1
10	3/8-16 X 3 BOLT	13115	2
11	3/8-16 UNC NUT	36304	2
12	BUSHINGS	QBWL-BC-1	2
13	GREASE ZERK	60102	2
14	CYLINDER	500010174	1
15	HYDRAULIC KIT	TIB-HK-2	1
16	HOSE CLAMP	1BAB6	1
17	3/8-16 X 3/4 BOLT	13103	1
18	3/8 LOCK WASHER	33622	3
19	BOLT ON EDGE	X310063	1
20	3/4 X 2 PLOW BOLTS	22705	10
21	3/4-10 NUTS	36316	10
22	INSTRUCTIONS	INST-WTB	1

WB WERK-BRAU CO., INC.
 2800 FOSTORIA AVE. P.O. BOX 545 FINDLAY, OHIO 45840-0545
 www.werkbrau.com PHONE: 419-422-2912 FAX: 419-422-7207

INCH	METRIC
1/X: ± 1/16	X: ± 1.50
.X: ± .1	X.X: ± 0.80
.XX: ± .01	X.XX: ± 0.25
.XXX: ± .005	ANGLE ± 0.5°
.XXXX: ± .0005	NOT TO SCALE

WELD SPEC: WELDS TO CONFORM TO P7.PRO6-WB ARC WELDING QUALITY STANDARD DATE: 4-20-18 WEIGHT: - Lbs.
 MACHINE: - PART No.: WTB5-60 FILE NAME: WTB5-60.CKD
 THIS PRINT AND THE INFORMATION CONTAINED HERE ON IS A CONFIDENTIAL DISCLOSURE, THE SUBJECT MATTER OF WHICH IS THE PROPERTY OF: WERK-BRAU CO., INC. DRAWN: REVISION **C**