

REV	DATE	CHANGE DESCRIPTION	BY	CHECKED
A	12-23-14	RELEASED TO PRODUCTION	JAS	-
B	1-21-15	UPDATE FOR STRONGER TILT TOP	JAS	-
C	9/11/23	UPDATED PACKLIST ITEM (#8,14,19) NAMES	BOK	-

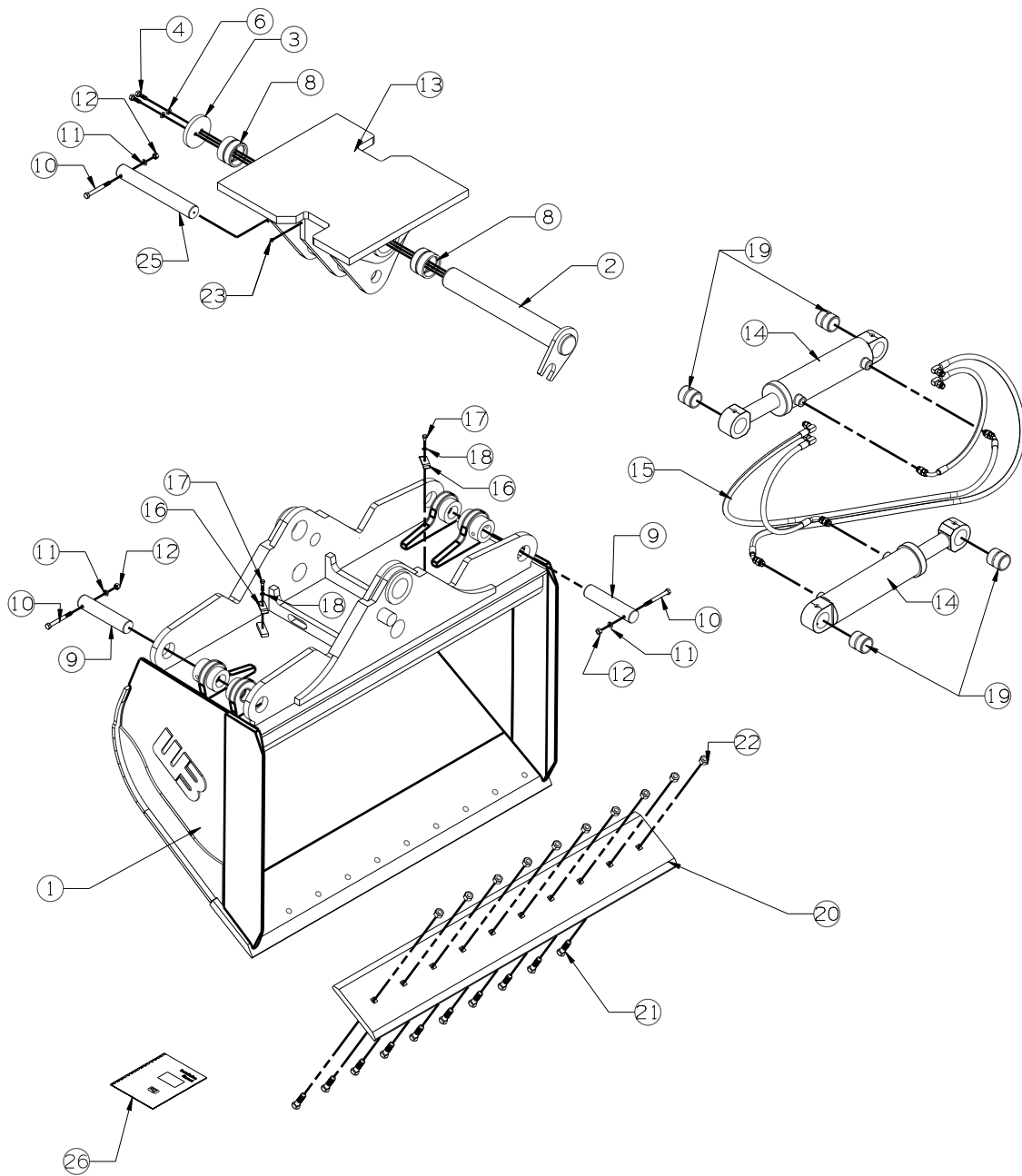

WTB66-1.52-PACKLIST

#	DESCRIPTION	PART #	AMT
1	WELDED ASSEMBLY	WTB66-1.52	1
2	PIVOT PIN	TIB-PP-14 (B)	1
3	PIVOT PIN CAP	EZGEX1-PC (B)	1
4	5/8-11 X 1 1/4 BOLT	13307 (B)	2
5	3/4-10 X 1 1/2 BOLT	13359 (B)	+
6	5/8 LOCK WASHER	33630 (B)	2
7	5/8-11 UNC NUT	36310 (B)	+
8	PIVOT BUSHING	EZG-BU-375-80	2
9	CYLINDER PIN	TIB-CP-09	2
10	1/2-13 UNC X 4 BOLT	13219	3
11	1/2 LOCK WASHER	33626	3
12	1/2-13 UNC NUT	36310	3
13	TILT TOP	TIB-TI-13 (B)	1
14	CYLINDER	700-4650	2
15	HOSE KIT	TIB-HK-4	1
16	HOSE CLAMP	D143846	2
17	3/8-16 UNC X 1 1/4 BOLT	13107	2
18	3/8 LOCK WASHER	33622	2
19	CYLINDER BUSHINGS	QBWL-BC-2	4
20	BOLT ON CUTTING EDGE	BOCE-1-10-66	1
21	3/4 X 3 PLOW BOLTS	22709	11
22	3/4-10 UNC NUTS	36316	11
23	GREASE ZERK	60102	1
24	3/4 LOCK WASHER	33632 (B)	+
25	CYLINDER PIN	TIB-CP-10	1
26	INSTRUCTIONS	INST-WTB	1

WB WERK-BRAU CO., INC.
 2800 FOSTORIA AVE. P.O. BOX 545 FINDLAY, OHIO 45840-0545
 www.werkbrau.com PHONE: 419-422-2912 FAX: 419-422-7207

INCH 1/X: ± 1/16 X: ± 1.50
 .X: ± .1 X.X: ± 0.80
 .XX: ± .01 X.XX: ± 0.25
 .XXX: ± .005 ANGLE ± 0.5°
 .XXXX: ± .0005 NOT TO SCALE

WELD SPEC: WELDS TO CONFORM TO P7.PRO6-WB ARC WELDING QUALITY STANDARD

DATE: 12-23-14

WEIGHT: - Lbs.

MACHINE: -

PART No.: WTB66-1.52

FILE NAME: WTB66-1.52.CKD

THIS PRINT AND THE INFORMATION CONTAINED HERE ON IS A CONFIDENTIAL DISCLOSURE, THE SUBJECT MATTER OF WHICH IS THE PROPERTY OF: WERK-BRAU CO., INC.

DRAWN:

C
REVISION

JAS