

REV	DATE	CHANGE DESCRIPTION	BY	CHECKED
A	1-14-15	RELEASED TO PRODUCTION	JAS	-
B	1-19-16	UPDATE FOR NEW STRONGER TOP	JAS	-
-	-	-	-	-

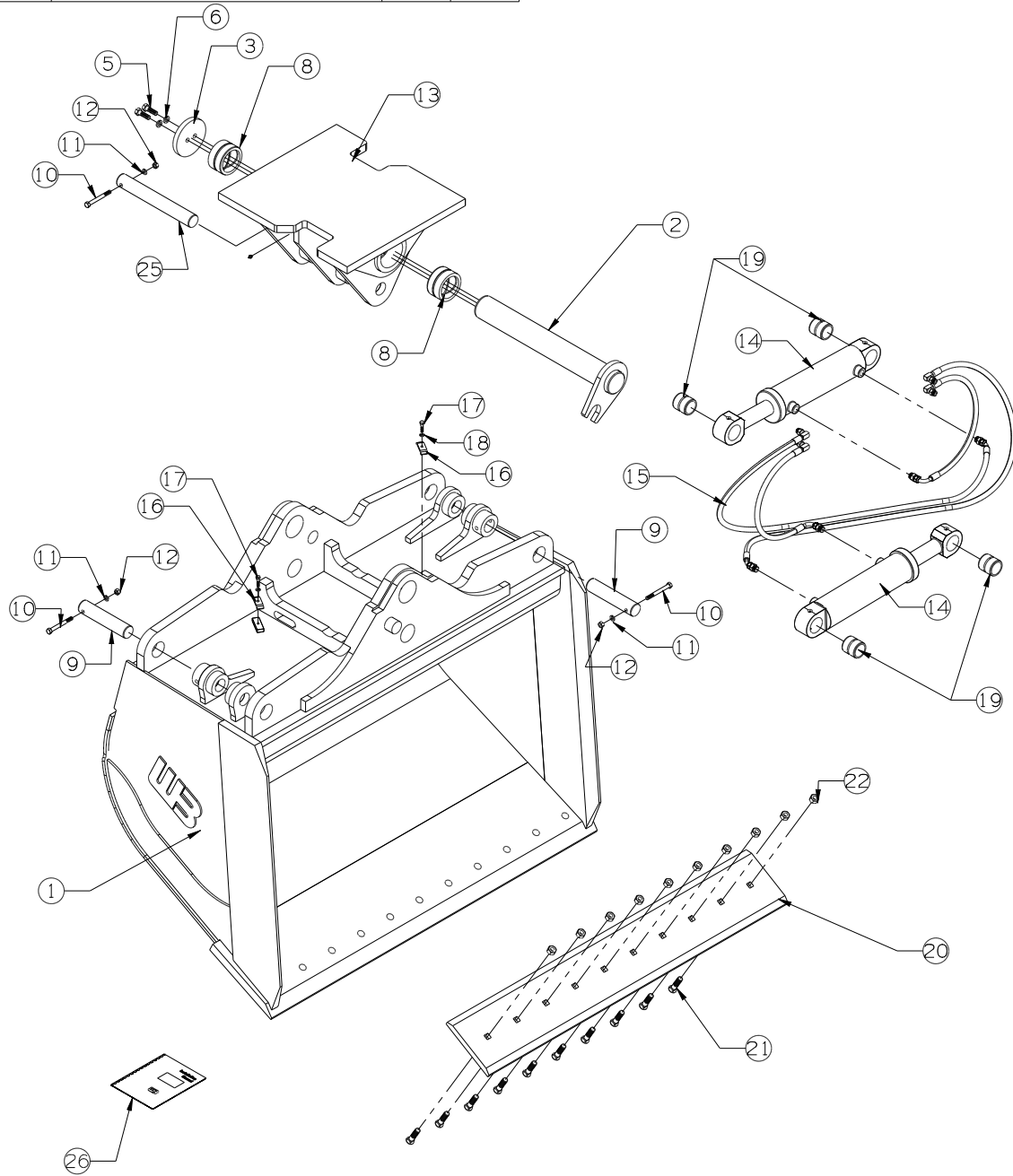

## WTB66-2.07-PACKLIST

#	DESCRIPTION	PART #	AMT
1	WELDED ASSEMBLY	WTB66-2.07	1
2	PIVOT PIN	TIB-PP-13 (B)	1
3	PIVOT PIN CAP	EZGEX2-PC (B)	1
4	5/8-11 X 6 BOLT	13325 (B)	1
5	3/4-10 X 1 1/2 BOLT	13359 (B)	2
6	3/4 LOCK WASHER	33630 (B)	2
7	5/8-11 UNC NUT	36310 (B)	1
8	PIVOT BUSHING	EZG-BU-450-90	2
9	CYLINDER PIN	TIB-CP-09	2
10	1/2-13 UNC X 4 BOLT	13219	3
11	1/2 LOCK WASHER	33626	3
12	1/2-13 UNC NUT	36310	3
13	TILT TOP	TIB-TI-14 (B)	1
14	CYLINDER	600-4650	2
15	HOSE KIT	TIB-HK-4	1
16	HOSE CLAMP	D143846	2
17	3/8-16 UNC X 1 1/4 BOLT	13107	2
18	3/8 LOCK WASHER	33622	2
19	CYLINDER BUSHINGS	TIB-BC-03	4
20	BOLT ON CUTTING EDGE	BOCE-1.25-12-66	1
21	1 X 3 1/2 PLOW BOLTS	22751	11
22	1-8 UNC NUTS	36320	11
23	GREASE ZERK	60102	2
24	3/4 LOCK WASHER	33632	1
25	CYLINDER PIN	TIB-CP-12	1
26	INSTRUCTIONS	INST-WTB	1



**WERK-BRAU CO., INC.**  
 2800 FOSTORIA AVE. P.O. BOX 545 FINDLAY, OHIO 45840-0545  
 www.werkbrau.com PHONE: 419-422-2912 FAX: 419-422-7207

INCH  
 1/X: ± 1/16  
 .X: ± .1  
 .XX: ± .01  
 .XXX: ± .005  
 .XXXX: ± .0005  
 METRIC  
 X: ± 1.50  
 X.X: ± 0.80  
 X.XX: ± 0.25  
 ANGLE ± 0.5°  
 NOT TO SCALE

WELD SPEC: WELDS TO CONFORM TO P7.PRO6-WB ARC WELDING QUALITY STANDARD

DATE: 1-14-15

WEIGHT: - Lbs.

MACHINE: -

PART No.: WTB66-2.07

FILE NAME: WTB66-2.07.CKD

THIS PRINT AND THE INFORMATION CONTAINED HERE ON IS A CONFIDENTIAL DISCLOSURE, THE SUBJECT MATTER OF WHICH IS THE PROPERTY OF: WERK-BRAU CO., INC.

DRAWN:

**B**  
 REVISION

